

DRUMS les Batteries

Baterias

BATTERIE

MAPEX



THE
WORLD
BEAT

MAPEX®

Mapex Percussion Technology proudly offers the ultimate line of professionally engineered drums and hardware. The combination of worldwide acoustical and technical research has given Mapex the capability that ensures consistently high performance from all Mapex drums.

MAPEX®

MAPEX Percussion Technology präsentiert eine Qualitätslinie von Professional Drums und Hardware. Modernste Entwicklung, Craftmanship und Produktion kombiniert mit Ideen von Drummerern rund um den Globus machen MAPEX mit zur ersten Wahl für Drummer weltweit.

La tecnología de Mapex ofrece una línea profesional de baterías y herrajes de calidad. Las nuevas técnicas de investigación, ingeniería y producción combinadas con ideas y aportaciones de bateristas de todo el mundo hace de Mapex la nueva opción para todos los bateristas.

*The Mapex factory
in Taipei, Taiwan*

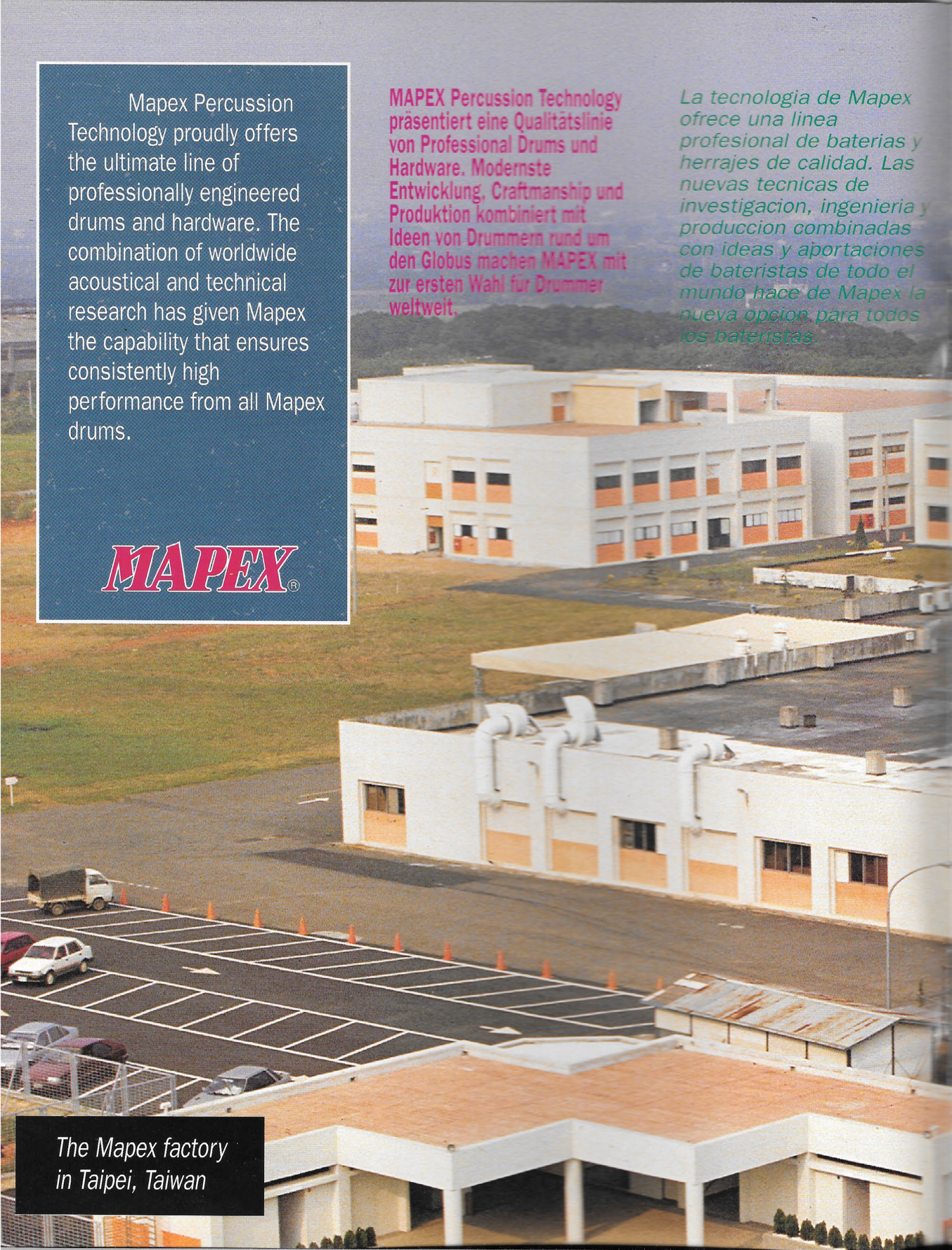

La tecnologia Mapex applicata alle percussioni consente di offrire una linea di strumenti ed accessori di qualità professionale. I più moderni sistemi di ricerca, ingegnerizzazione e produzione combinati con le idee dei migliori batteristi, fanno di Mapex la nuova scelta degli artisti di tutto il mondo.

La qualité du travail fait main de Mapex.

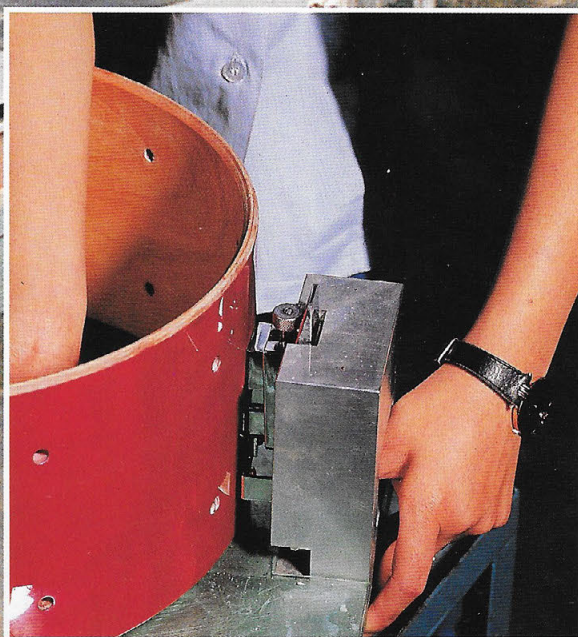
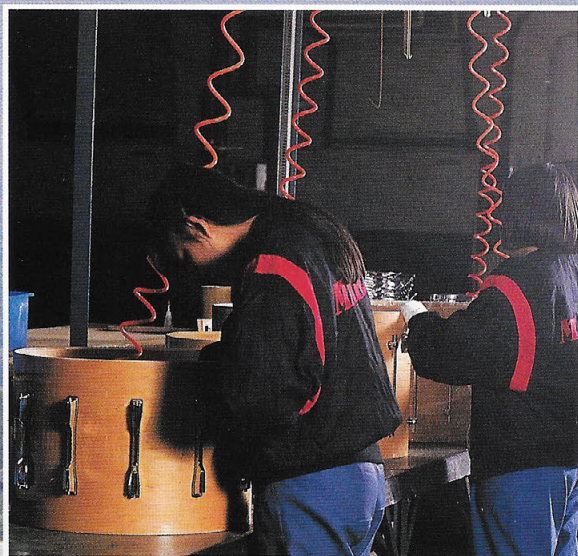

PERFORMANCE DESIGNED

The artist's experience and knowledge contributes greatly to a product's final design.

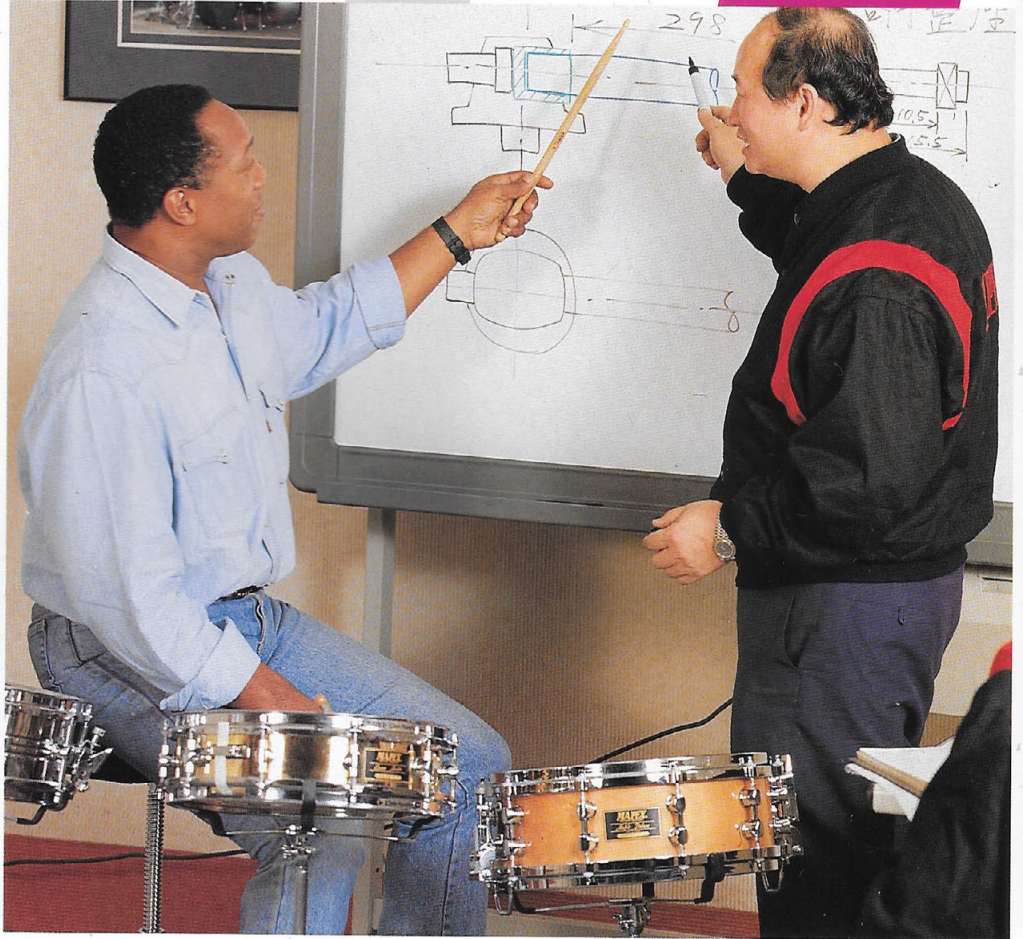

Ils sont fabriqués et mis au point par une équipe de professionnels pour des professionnels

COLABORAN EN EL DISEÑO Y DESARROLLO

Progettata in collaborazione coi migliori batteristi

PROFESSIONELLE DRUMMER BRINGEN IHRE ERFAHRUNG UND IHR KNOW HOW IN PRODUKTION UND DESIGN EIN

PROFESSIONAL SERIES FEATURES

Numerous features of the Mapex drums and hardware are totally unique to Mapex and are protected under Patents Pending worldwide.

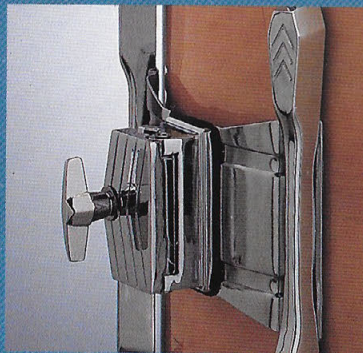

Orion "Zero Contact" tom mounting system connects without any contact to the drum shell.



The longer lever of the "Pro-Lok" allows for up to 170 pounds of hand pressure.

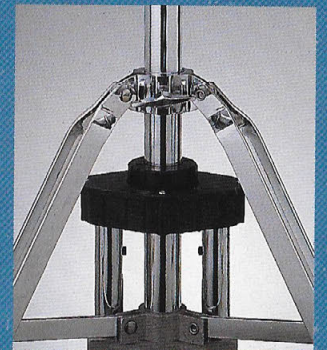

Double spring hi hat tension is adjusted with a single gear for quick and easy access from a seated position.

THE WORLD BEAT

WORLDWIDE ENDORSEES

Players worldwide have discovered Mapex. The sound and durability of Mapex is proven daily on the stage and in studios from one end of the globe to the other. Mapex — providing “The World Beat.”



BILLY COBHAM

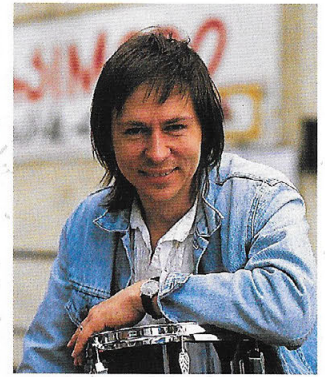

CHRIS EVANS
Germany



MIKE TERRANA
Mac Alpine/USA

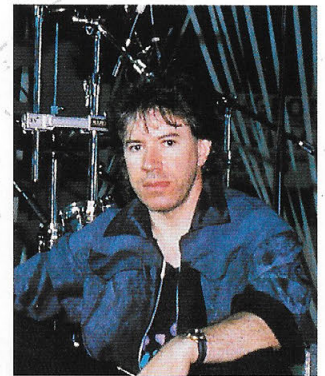

ANGEL CELADA
Spain



MICHAEL WITZEL
Germany



STEVE “DR. KILLDRUMS”
WALCHOLZ—Savatage/USA



SEAN BURKE—Atlanta
Rhythm Section/USA



STEVE CLARK
England



DAVID “ACE” ALLEN
Marshall Tucker Band/USA

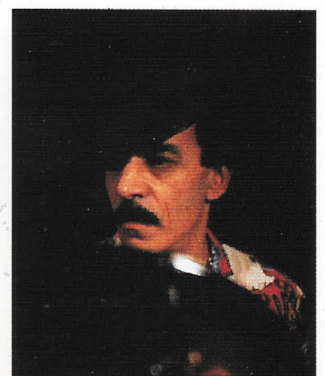

PORTINHO
Brazil

THE WORLD BEAT

ORION CUSTOM MAPLE

The choice of the professional drummer who desires the strength and well balanced, warm sound of Canadian Maple. Shells are six ply laminated and diagonally cut at precisely 15 degrees to ensure perfect roundness and enhance strength. All drum shells receive Mapex's unique eleven step, high gloss finish. Patented "Freedom" high tension lugs are full length style mounted 4mm off the shell to provide maximum resonance. Toms have "Zero Contact" tom mount as do floor tom brackets.



"Zero Contact" tom holders



"Zero Contact" floor tom legs

Coquilles "Freedom"

Avec l'attache tom "Zero-Contact"

Érable canadien

Pieds double embasc

Finitura Laccata Lucida

Fusti in Acero

Attacchi Reggitom "Zero Contact"

Fusti a Sei Strati

HOCHGLANZLACKIERUNG

SECHSSCHICHTIGE AHORN KESSEL
"ZERO CONTACT" TOM HALTERUNG

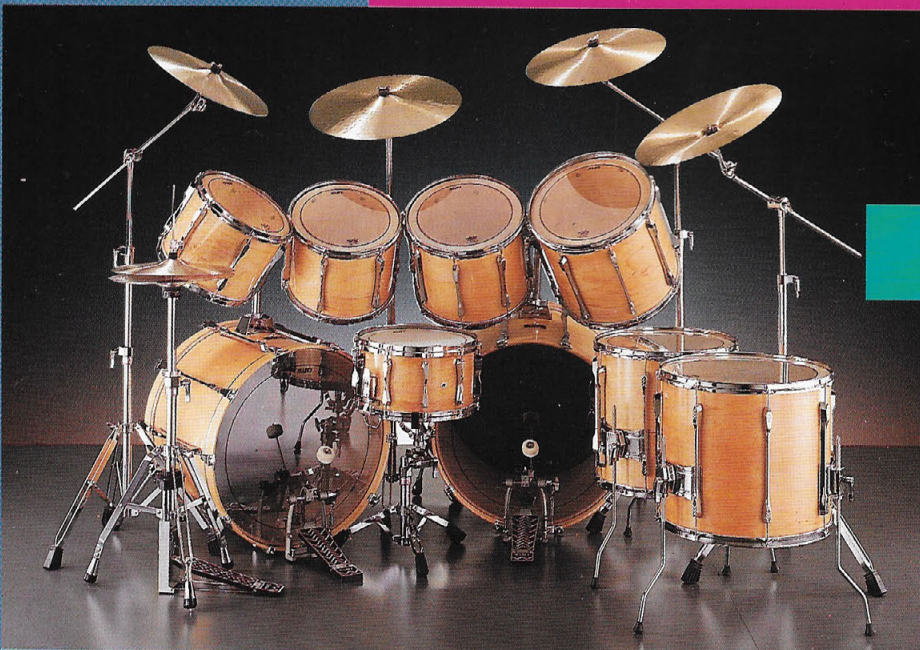

MPL94D

#151 Natural Maple



SEAN BURKE
Atlanta Rhythm
Section



DAVID TEEGARDEN
Bob Seger's Silver
Bullet Band



MADERA DE ARCE ACABADOS EN LACA TRANSPARENTE BRILLANTE
CASCOS DE SEIS CAPAS SOPORTES DE TOM TOM "ZERO CONTACT"



Freedom Lugs

MPL94D

#153 Transparent Red

- | | |
|------------|----------|
| MPLB24 (2) | S700 |
| MPLT 12 | H700 |
| MPLT13 | C700 |
| MPLT14 | B700 (3) |
| MPLT15 | P700 (2) |
| MPLF16 | TH68 (2) |
| MPLF18 | |
| B480DH | |
| *MS480DH | |

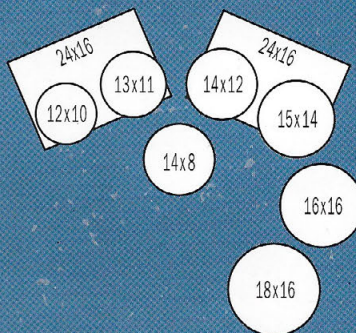



MPL7
#151
Natural Maple

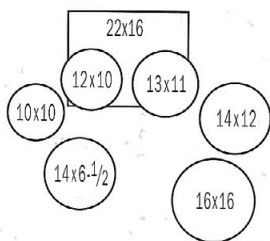

- MPLB22
- MPLT10
- MPLT12
- MPLT13
- MPLT14
- MPLF16
- MS465DH
- S700
- H700
- C700
- B700
- P700
- TH68
- TH69 (2)
- AC901 (2)

							ORION CUSTOM SERIE							
								MPL5	MPL54	MPL6	MPL7	MPL74	MPL9D	MPL94D
mit Ahorn Spannreifen	BASS DRUM	Grosse Caisse	22 x 16 24 x 16	BOMBO	MPLB22 MPLB24	Cassa	●		●	●	●		●●	●●
mit Zero Contact Tom Halterung	TOM TOM	avec L'attache Tom "Zero Contact"	10 x 10	CON SOPORTE DE TOM-TOMS "ZERO CONTACT"	MPLT10	Tom con Attacco "Zero Contact"			●	●			●	●
			12 x 10		MPLT12				●	●	●	●		
			13 x 11		MPLT13				●	●	●	●		
			14 x 12		MPLT14				●	●	●	●		
			15 x 14		MPLT15				●	●	●	●		
Stand Tom	FLOOR TOM	Tom Basse	16 x 16 18 x 16	TIMBAL BASE	MPLF16 MPLF18	Timpano	●		●	●		●	●	
Snare Drum	SNARE DRUM	maple brass *maple	Caisse Claire érable laiton *érable	14 x 6-1/2 14 x 8 *14 x 8	arce metálica *arce	MS465DH B480DH **MS480DH	acero Rullante ottone *acero	●		●	●		●	●
Komplett Justierbar	SNARE STAND	Support de Caisse Claire	🔧	SOPORTE DE CAJA	S700	Reggirullante	●	●	●	●	●		●	●
Doppelstrebüg	HI-HAT STAND	Pédale de Cymbale	🔧	SOPORTE DE CHASTON	H700	Charleston	●	●	●	●	●		●	●
Beckenständer Gerade	CYMBAL STAND	Support de Cymbale	🔧	SOPORTE DE PLATO	C700	Reggiplatto	●	●	●	●	●		●	●
Galgen Beckenständer	CYMBAL BOOM STAND	Support de Cymbale à Perche	🔧	SOPORTE DE PLATO JIRAFÁ	B700	Reggiplatto a Giraffa	●	●	●	●	●		●●●	●●●
Fußmaschine	FOOT PEDAL	Pédale Grosse Caisse	🔧	PEDAL DE BOMBO	P700	Pedale	●	●	●	●	●		●●	●●

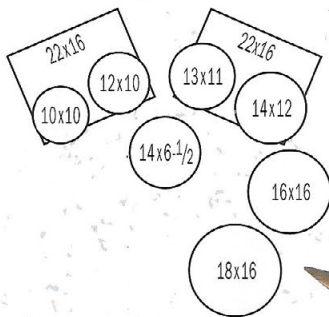

MPL9D
#155 Transparent Black

- MPLB22 (2)
- MPLT10
- MPLT12
- MPLT13
- MPLT14

- MPLF16
- MPLF18
- MS465DH
- S700
- H700

- C700
- B700 (3)
- P700 (2)
- TH68 (2)



On MPL74 Natural matching snare drum replaces the brass snare drum



MPL74

#152 Transparent Cobalt Blue

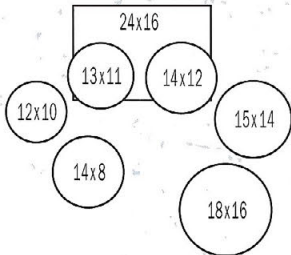

- MPLB24
- MPLT12
- MPLT13
- MPLT14
- MPLT15
- MPLF18
- B480DH
- *MS480DH
- S700
- H700
- C700
- B700
- P700
- TH68
- TH69 (2)
- AC901 (2)

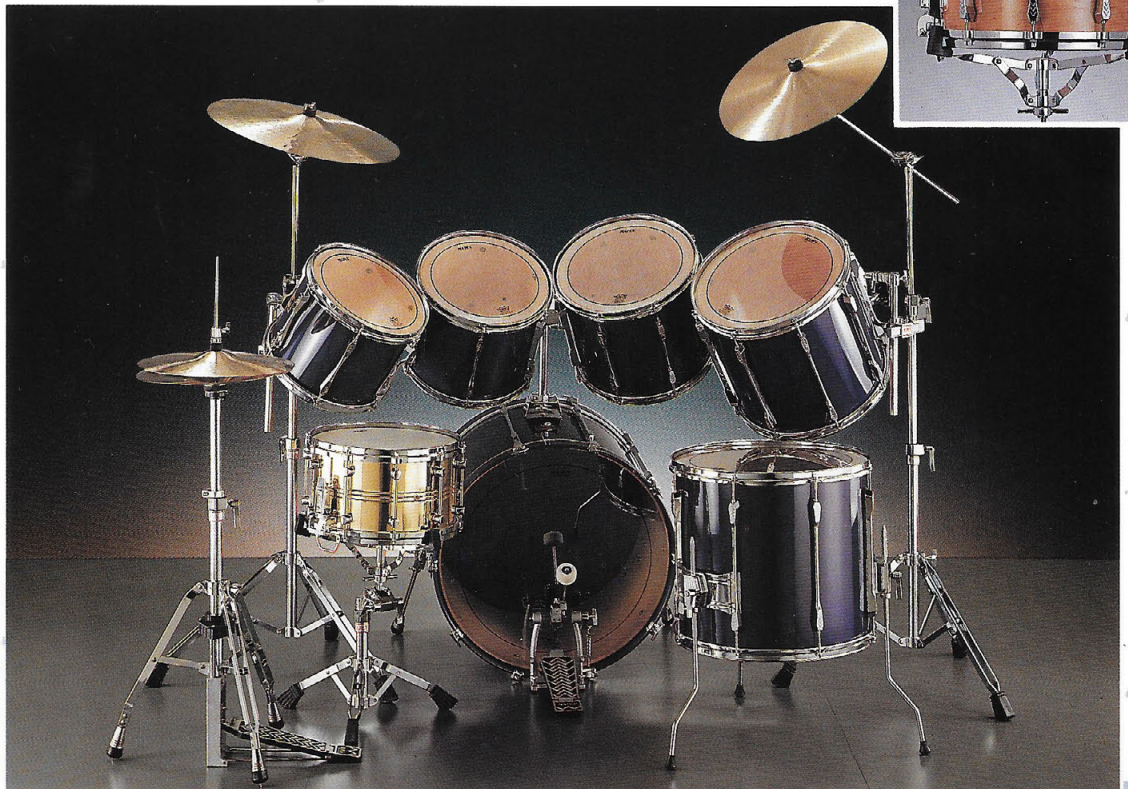



MPL54

#153 Transparent Red

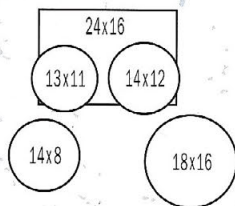

- MPLB24 S700
- MPLT13 H700
- MPLT14 C700
- MPLF18 B700
- B480DH P700
- *MS480DH TH68

On MPL54 Natural a maple snare drum replaces the brass snare drum



ADD-ON TOMS

Zusätzlich Erhältliche Toms, Klemmen und Tomarme

SUETOS
TOM-TOMS

Tom Aggiuntivi
Con Kit
Di Montaggio



MPLT8
MPLT10



MPLT14

MPLT16

TH69/AC901



TS700



MPL5
#155 Transparent Black

MPLB22	S700
MPLT12	H700
MPLT13	C700
MPLF16	B700
MS465DH	P700
	TH68

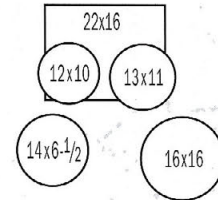

MPL6
#151 Natural Maple

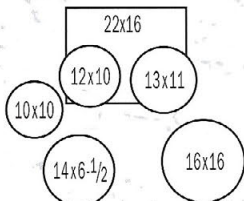

MPLB22	S700
MPLT10	H700
MPLT12	C700
MPLT13	B700
MPLF16	P700
MS465DH	TH68
	TH69
	AC901



ORION CUSTOM COLORS (Lacquer Finish)

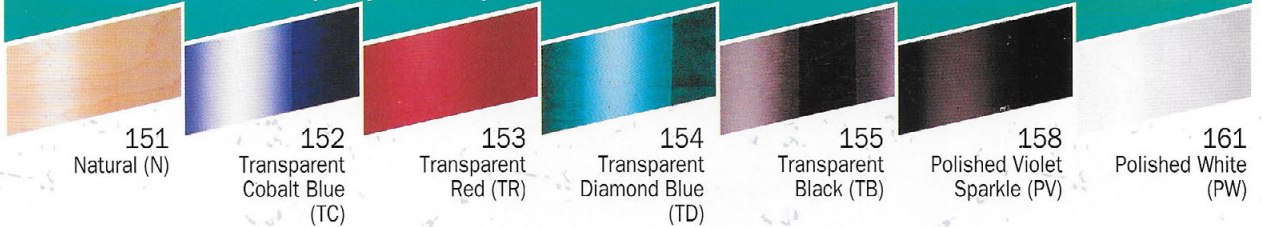

THE WORLD BEAT

ORION STUDIO BIRCH

Orion Studio was designed for those who prefer the brilliant resonance and hard, fast attack of North American Birch shells. Each shell is 8mm thick and cross-laminated in six plies. Standard on all Orion outfits are "Freedom" high tension lugs and "Zero Contact" tom and floor tom mounts that optimize maximum shell resonance. Also, the extra heavy-duty "Pro-Lok" hardware provides maximum stability and fast adjustments.

NORDAMERIKANISCHE BIRKE

DOPPELSTREBIGE "PRO-LOCK" HARDWARE

DURCHGEHENDE "HIGH TENSION" BÖCKCHEN

Accessoire double embase avec "Pro-Lok" • Fût en bouleau



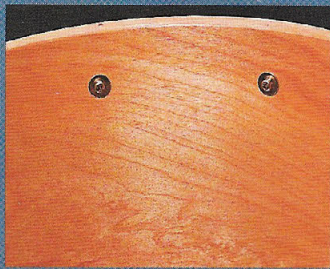

Six-ply, North American birch shells



Matching wood bass drum hoops

Betulla Nord Americana
"Pro-Lok" Gambe a Doppio Stelo
Blocchetti Tiranti Lunghi

TENSORES LONGITUDINALES CONTINUOS
 ABEDUL DE NORTE AMERICA
 "PRO-LOK"
 HERRAJES DE DOBLE PERFIL

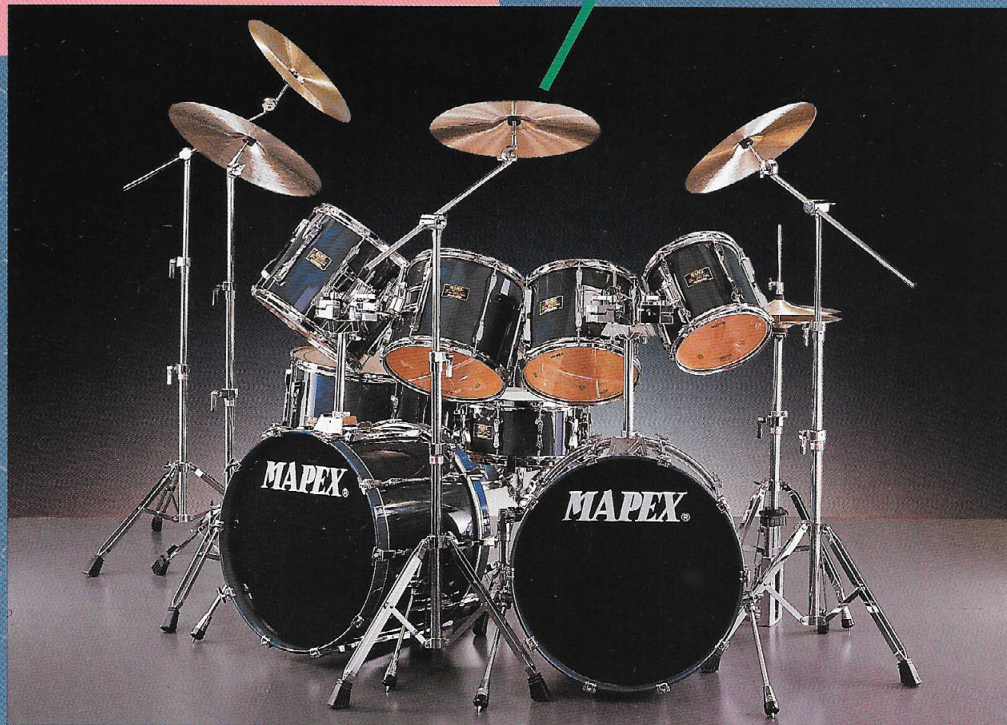

BHL94D
 #161 Polished White

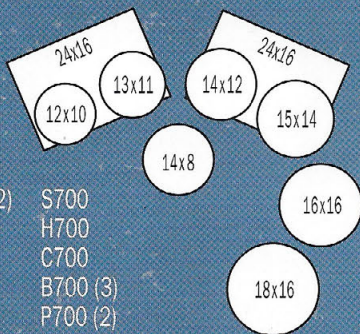

- BHLB24 (2) S700
- BHLT12 H700
- BHLT13 C700
- BHLT14 B700 (3)
- BHLT15 P700 (2)
- BHLF16 TH68 (2)
- BHLF18
- B480

BHL9D
 #154 Transparent Diamond Blue

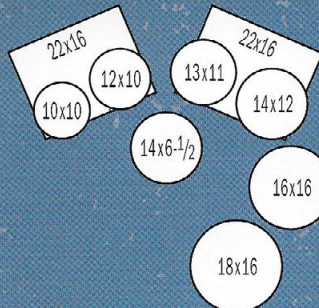

- BHLB22 (2) S700
- BHLT10 H700
- BHLT12 C700
- BHLT13 B700 (3)
- BHLT14 P700 (2)
- BHLF16 TH68 (2)
- BHLF18
- BS465

						ORION STUDIO SERIE						
						BHL5	BHL54	BHL6	BHL7	BHL74	BHL9D	BHL94D
mit Ahorn Spannreifen	BASS DRUM	Grosse Caisse	22 x 16 24 x 16	BOMBO	BHLB22 BHLB24	Cassa	●	●	●	●	●●	●●
mit Zero Contact Tom Halterung	TOM TOM	avec L'attache Tom "Zero Contact"	10 x 10 12 x 10 13 x 11 14 x 12 15 x 14	CON SOPORTE DE TOM-TOMS "ZERO CONTACT"	BHLT10 BHLT12 BHLT13 BHLT14 BHLT15	Tom con Attacco "Zero Contact"	●	●	●	●	●	●
Stand Tom	FLOOR TOM	Tom Basse	16 x 16 18 x 16	TIMBAL BASE	BHLF16 BHLF18	Timpano	●	●	●	●	●	●
Snare Drum	SNARE DRUM	birke verchromat messing Caisse Claire	bouleau chromé laiton 14 x 6-1/2 14 x 8 14 x 8	abedul cromado metálica CAJA	BS465 S480 B480	bettula cromato ottone Rullante	●	●	●	●	●	●
Komplett Justierbar	SNARE STAND	Support de Caisse Claire		SOPORTE DE CAJA	S700	Reggriullante	●	●	●	●	●	●
Doppelstrebige	HI-HAT STAND	Pédale de Cymbale		SOPORTE DE CHASTON	H700	Charleston	●	●	●	●	●	●
Beckenständer Gerade	CYMBAL STAND	Support de Cymbale		SOPORTE DE PLATO	C700	Reggiplatto	●	●	●	●	●	●
Galgan Beckenständer	CYMBAL BOOM STAND	Support de Cymbale à Perche		SOPORTE DE PLATO GIRAFIA	B700	Reggiplatto a Giraffa	●	●	●	●	●●●	●●●
Fußmaschine	FOOT PEDAL	Pédale Grosse Caisse		PEDAL DE BOMBO	P700	Pedale	●	●	●	●	●●	●●



BHL7
#154 Transparent
Diamond Blue

- | | |
|--------|-----------|
| BHLB22 | S700 |
| BHLT10 | H700 |
| BHLT12 | C700 |
| BHLT13 | B700 |
| BHLT14 | P700 |
| BHLF16 | TH68 |
| BS465 | TH69 (2) |
| | AC901 (2) |

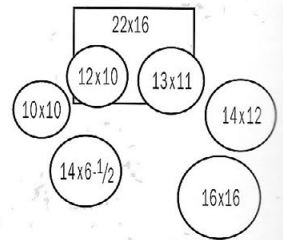

MITCH McLEE
Southgang



MIKE HANSEN
LA Studio

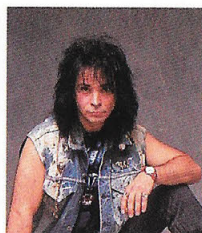

DAVID EAGLE
Mannic Distortion

BHL74

#161 Polished White

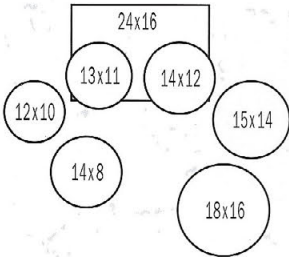

- | | |
|--------|-----------|
| BHLB24 | S700 |
| BHLT12 | H700 |
| BHLT13 | C700 |
| BHLT14 | B700 |
| BHLT15 | P700 |
| BHLF18 | TH68 |
| S480 | TH69 (2) |
| | AC901 (2) |



BHL6

#154 Transparent Diamond Blue

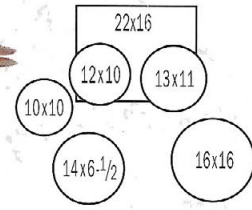

- | | |
|--------|-------|
| BHLB22 | S700 |
| BHLT10 | H700 |
| BHLT12 | C700 |
| BHLT13 | B700 |
| BHLF16 | P700 |
| BS465 | TH68 |
| | TH69 |
| | AC901 |



BHL5

#153 Transparent Red

- | | |
|--------|------|
| BHLB22 | S700 |
| BHLT12 | H700 |
| BHLT13 | C700 |
| BHLF16 | B700 |
| BS465 | P700 |
| | TH68 |

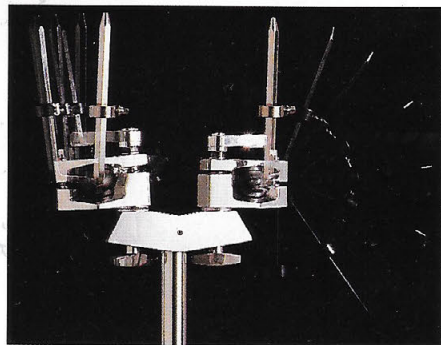
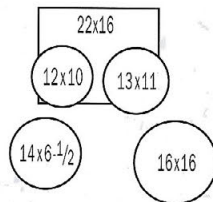

"Pro-Lok" 360° tom holder

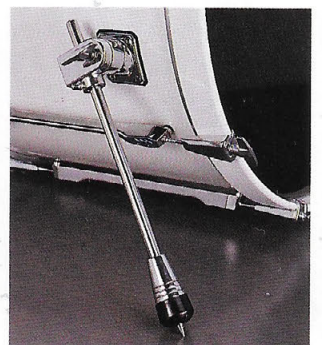

Orion "Memory" bass drum spurs



BHL54
#161 Polished White

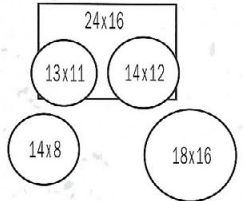

- | | |
|--------|------|
| BHLB24 | S700 |
| BHLT13 | H700 |
| BHLT14 | C700 |
| BHLF18 | B700 |
| B480 | P700 |
| | TH68 |

ADD-ON TOMS



BHLT8
BHLT10



BHLT14

BHLT16

TH69/AC901



TS700

ORION STUDIO COLORS (Lacquer Finish)

152 Transparent Cobalt Blue (TC)	153 Transparent Red (TR)	154 Transparent Diamond Blue (TD)	155 Transparent Black (TB)	158 Polished Violet Sparkle (PV)	161 Polished White (PW)

THE WORLD BEAT

SATURN

Designed for the professional who demands expressive sound quality with plenty of volume. Saturn shells are an exclusive seven ply design that fuse the clean, crisp sound of maple inside and out with the power and durability of

mahogany hardwoods. Drums feature the Mapex eleven step lacquer finish process. Saturn tension lugs only touch the shells in two contact points, greatly enhancing resonance, volume and projection.

**ACABADO EN LACA
TRANSPARENTE BRILLANTE
CASCO DE SIETE CAPAS EN
ARCE Y CAOBA
TENSORES LONGITUDINALES
CONTINUOS**

SL9D
#153 Transparent Red

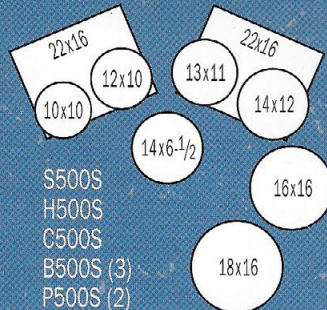

- SLB22 (2) S500S
- SLT10 H500S
- SLT12 C500S
- SLT13 B500S (3)
- SLT14 P500S (2)
- SLF16 TH68 (2)
- SLF18
- S465S

DURCHGEHENDE "HIGH TENSION" BÖCKCHEN



SIEBENSCHICHTIGE AHORN UND MAHOGANY KESSEL

						SATURN SERIE								
						SL4S	SL5	SL5S	SL6	SL7	SL7D	SL8D	SL9D	SL50
mit Ahorn Spannreifen	BASS DRUM	Grosse Caisse	20 x 14 22 x 16	BOMBO	SLB2014 SLB22	Cassa	•	•	•	•	•	•	•	•
mit Orion Tom Halterung	TOM TOM	avec L'attache Tom "Orion"	10 X 8	CON SOPORTE DE TOM-TOM "ORION"	SLT1008	Tom con Attacco "Orion"								•
			12 X 8		SLT1208								•	
			10 x 10		SLT10				•	•	•	•	•	•
			12 x 10		SLT12		•	•	•	•	•	•	•	
			13 x 11		SLT13		•	•	•	•	•	•	•	•
	14 x 12		SLT14			•				•				
Stand Tom	FLOOR TOM	Tom Basse	14 x 14 16 x 16 18 x 16	TIMBAL BASE	SLF1414 SLF16 SLF18	Timpano	•	•	•	•	•	•	•	•
Snare Drum	SNARE DRUM	brass Caisse maple Claire verchromat chrome	14 x 3-1/2 14 X 5 14 x 6-1/2	CAJA	ottone B435 arce MS450S cromado S465S	Rullante					•			•
Komplett Justierbar	SNARE STAND	Support de Caisse Claire		SOPORTE DE CAJA	S500S	Reggirullante		•		•	•	•	•	(S300M)
Doppelstrebig	HI-HAT STAND	Pédale de Cymbale		SOPORTE DE CHASTON	H500S	Charleston		•	•	•	•	•	•	(H300M)
Beckenständer Gerade	CYMBAL STAND	Support de Cymbale		SOPORTE DE PLATO	C500S	Reggipiatto		•	•	•	•	•	•	(C300M)
Galgen Beckenständer	CYMBAL BOOM STAND	Support de Cymbale à Perche		SOPORTE DE PLATO JIRAFÁ	B500S	Reggipiatto a Giraffa		•	•	•	•	•	•	(B300M)
Fußmaschine	FOOT PEDAL	Pédale Grosse Caisse		PEDAL DE BOMBO	P500S	Pedale		•	•	•	•	•	•	(P500)

Fùt en acajou

Coquilles "High Tension"

Fusti in Acero e Mogano
Finitura Laccata Lucida
Blocchetti Tiranti Lunghi
Fusti a Sei Strati

SL8D

#155 Transparent
Black

- SLB22 (2) S500S
- SLT10 H500S
- SLT12 C500S
- SLT13 B500S (2)
- SLT14 P500S (2)
- SLF16 TH68 (2)
- B435

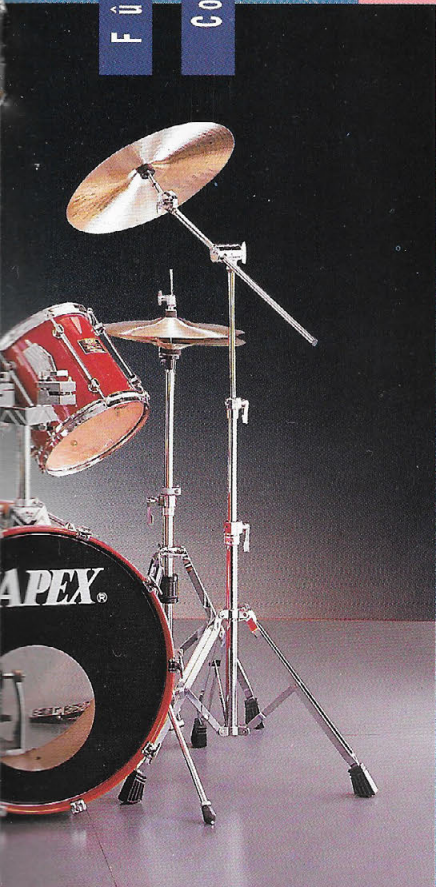
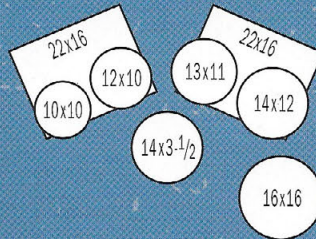

HOCHGLANZLACKIERUNG

SL7D

#153 Transparent
Red

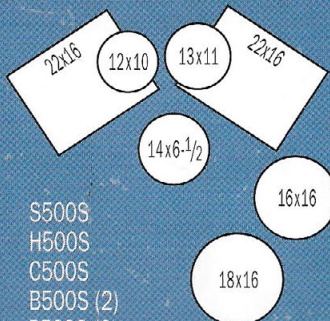

- SLB22 (2) S500S
- SLT12 H500S
- SLT13 C500S
- SLF16 B500S (2)
- SLF18 P500S (2)
- S465S TS500S



SL7

#155 Transparent Black

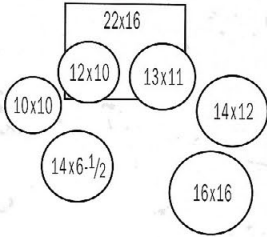

- SLB22
- SLT10
- SLT12
- SLT13
- SLT14
- SLF16
- S465S
- S500S
- H500S
- C500S
- B500S
- P500S
- TH68
- TH69 (2)
- AC901 (2)



SATURN



SL6

#155 Transparent Black

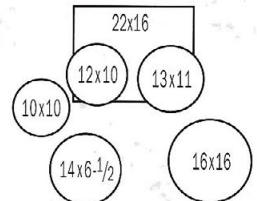

- SLB22
- SLT10
- SLT12
- SLT13
- SLF16
- S465S
- S500S
- H500S
- C500S
- B500S
- P500S
- TH68
- TH69
- AC901

SL5
#153 Transparent Red

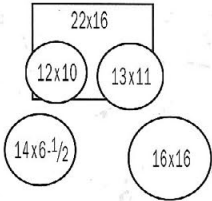

- SLB22
- SLT12
- SLT13
- SLF16
- S465S
- S500S
- H500S
- C500S
- B500S
- P500S
- TH68

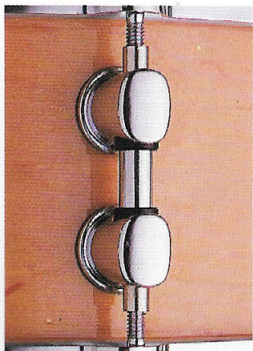

2-point contact lugs



Shell laminations are cut at precisely 15°

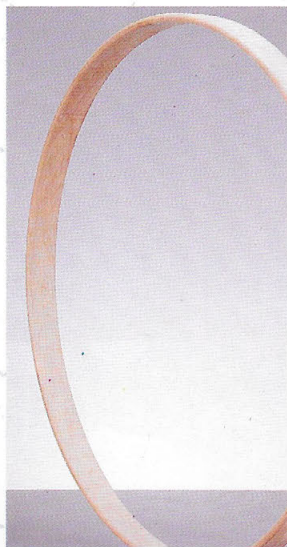

Saturn maple bass drum hoops

Batteria Senza Supporti



**KESSELSET
OHNE STÄNDER**

SL5S

Wood shells with snare drum

**ELEMENTOS SUELTOS
SIN SOPORTES**

SL4S

Wood shells only (without snare drum)

SL50 Saturn Philadelphia

#191 Matt Natural

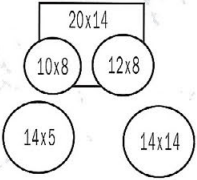

- SLB2014
- SLT1008
- SLT1208
- SLF1414
- MS450S
- S300M
- H300M
- C300M
- B300M
- P500
- TH66 (2)

SATURN



ADD-ON TOMS

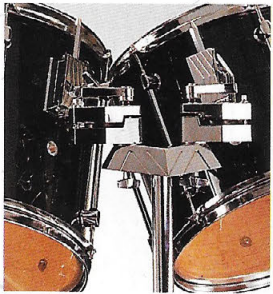

Orion tom holders



Rotating bass drum spurs



TS500S



SLT8
SLT10



SLT14

SLT16

TH69/AC901

SATURN COLORS (Lacquer Finish)



152
Transparent
Cobalt Blue
(TC)



153
Transparent
Red (TR)



154
Transparent
Diamond Blue
(TD)



155
Transparent
Black (TB)



161
Polished White
(PW)

SATURN Philadelphia



191
Matt Natural
(MN)

MARS

Mars nine ply cross laminated hardwood shells with choice wood grain interiors provide rich sound with great projection and volume. Sleek designed, full-length lugs are mounted off the face of each drum to allow the shell greater freedom to vibrate and project. The heavy hardware features the unique Mapex "Pro-Lok" system of adjustment.

NUEVE CAPAS DE MADERA SELECCIONADA
TENSORES LONGITUDINALES CONTINUOS
SOPORTE DE TIMBAL REGULABLE

Accessoire lourd à simple embase • Fût 9 plis

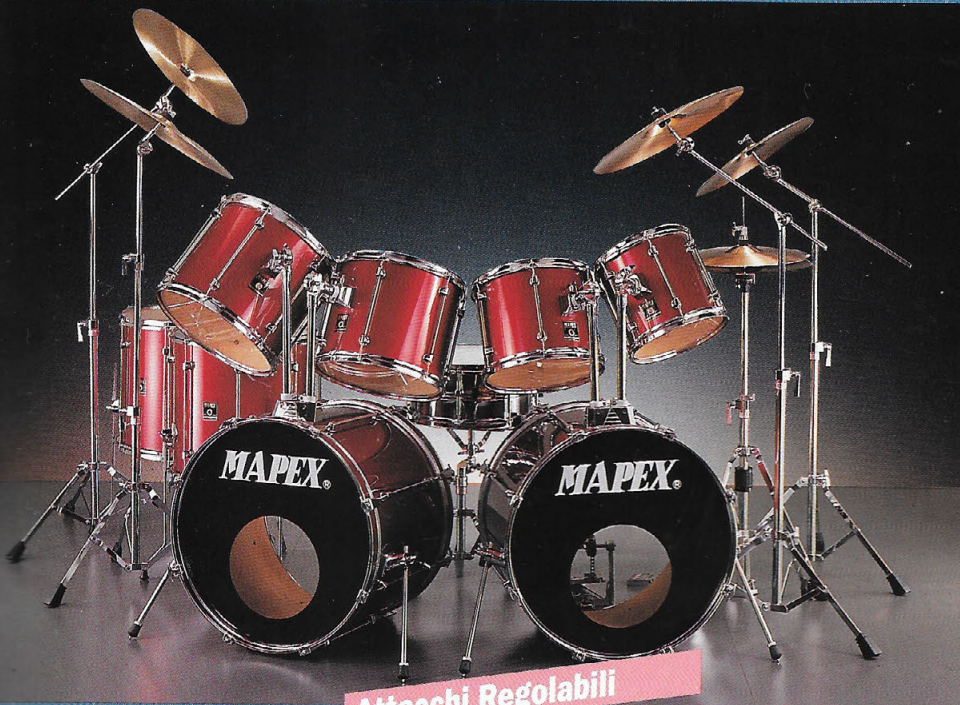

Attacchi Regolabili
Fusti a Nove Strati
Blocchetti Tiranti Lunghi

M8D

#134 Wine Red

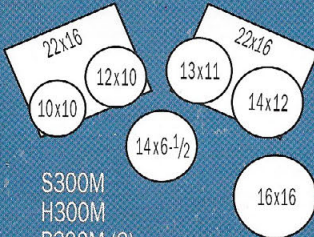

- MB22 (2)
- MT10
- MT12
- MT13
- MT14
- MF16
- S465M
- S300M
- H300M
- B300M (2)
- P300M (2)
- TH66 (4)

M9D

#134 Wine Red

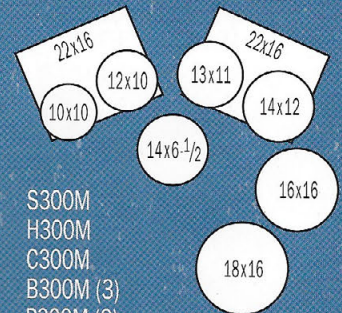

- MB22 (2)
- MT10
- MT12
- MT13
- MT14
- MF16
- MF18
- S465M
- S300M
- H300M
- C300M
- B300M (3)
- P300M (2)
- TH66 (4)



NEUNSCHICHTIGE HARHOLZ KESSELL
DURCHGEHENDE "HIGH TENSION" BÖCKCHEN



M7D

#132 Jet Black

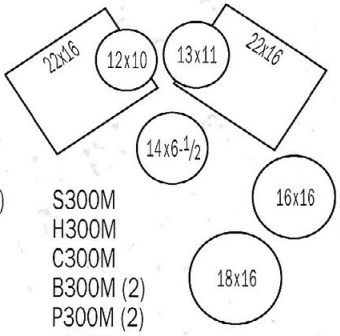

- MB22 (2)
- MT12
- MT13
- MF16
- MF18
- S465M
- S300M
- H300M
- C300M
- B300M (2)
- P300M (2)
- TS300M

M7

#134 Wine Red

- MB22
- MT10
- MT12
- MT13
- MT14
- MF16
- S465M
- S300M
- H300M
- C300M
- B300M
- P300M
- TH66 (4)
- AC901 (2)
- OPTION TH66 (2) with TS300M

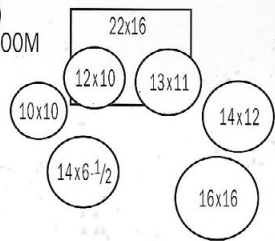

MARS

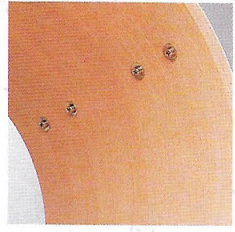

Select hardwood 9-ply shells

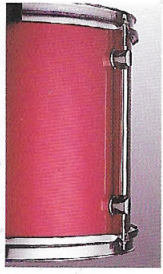

Sleek full length lugs

ADD-ON TOMS

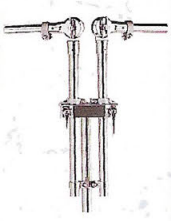

TS300M



MT8
MT10



MT14

TH66/AC901
MT16

						MARS SERIE							
						M4S	M5	M5S	M7	M7D	M8D	M9D	MP5
mit Verchromten Spannreifen	BASS DRUM	Grosse Caisse	22 x 16 22 x 16	BOMBO	MPB22 MB22	Cassa							
mit Justierbarer Tom Halterung	TOM TOM	avec L'attache Tom Regable	12 x 10 13 x 11 10 x 10 12 x 10 13 x 11 14 x 12	CON SOPORTE DE TIMBAL REGULABLE	MPT12 MPT13 MT10 MT12 MT13 MT14	Tom con Attacco Regolabile							
Stand Tom	FLOOR TOM	Tom Basse	16 x 16 16 x 16 18 x 16	TIMBAL BASE	MPF16 MF16 MF18	Timpano							
Snare verchromat Drum	SNARE DRUM	chrome Caisse chromé	14 x 6-1/2 14 x 6-1/2	CAJA cromado cromado	S465S S465M	Rullante cromato cromato							
Komplett Justierbar	SNARE STAND	Support de Caisse Claire		SOPORTE DE CAJA	S300M	Reggirullante							(S500S)
Einstrebig	HI-HAT STAND	Pédale de Cymbale		SOPORTE DE CHASTON	H300M	Charleston							(H500S)
Beckenständer Gerade	CYMBAL STAND	Support de Cymbale		SOPORTE DE PLATO	C300M	Reggiplatte							(C500S)
Galgen Beckenständer	CYMBAL BOOM STAND	Support de Cymbale à Perche		SOPORTE DE PLATO GIRAFFA	B300M	Reggiplatte a Giraffa							
Fußmaschine	FOOT PEDAL	Pédale Grosse Caisse		PEDAL DE BOMBO	P300M	Pedale							(P500S)

M5

#131 Smokey Chrome

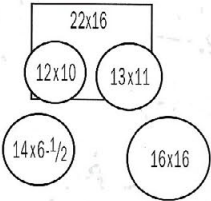

- | | |
|-------|----------|
| MB22 | S300M |
| MT12 | H300M |
| MT13 | C300M |
| MF16 | P300M |
| S465M | TH66 (2) |



M5 PRO

#161 Polished White

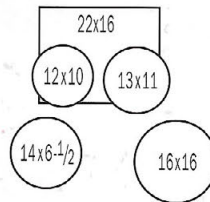

- | | |
|-------|----------|
| MPB22 | S500S |
| MPT12 | H500S |
| MPT13 | C500S |
| MPF16 | P500S |
| S465S | TH66 (2) |

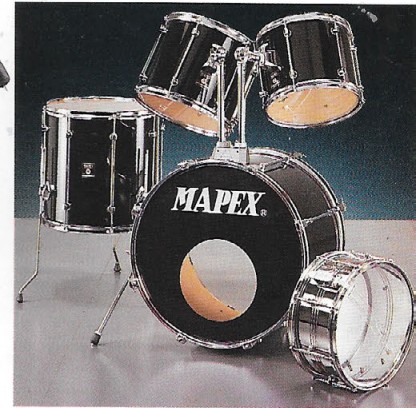

M5S

Wood shells with
snare drum

M4S

Wood shells only
(without snare drum)



MARS COLORS (Metallic Finish)



M5PRO COLORS (Lacquer Finish)

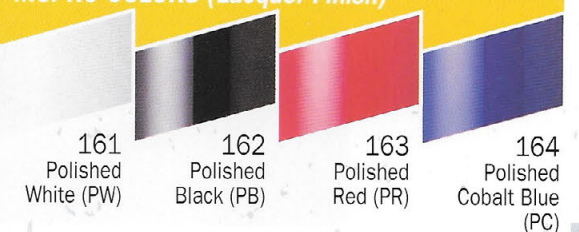

CAJAS

SNARE DRUMS

C a i s s e s C l a i r e s

Rullanti

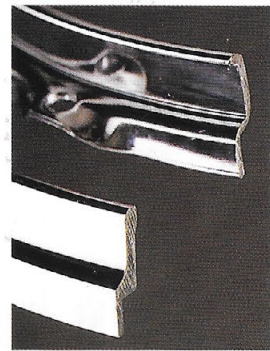

Power Hoop

Die-Cast Hoop

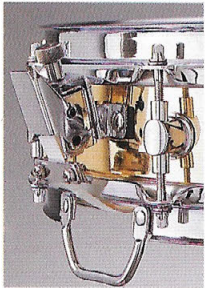

Piccolo snare strainer—one point contact

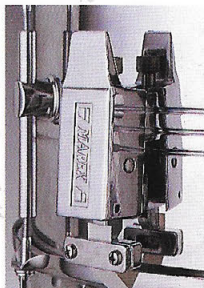

Throw-off snare strainer



"Freedom" high tension lugs—throw-off strainer

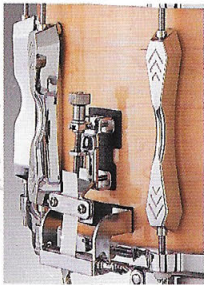

Adjustable butt throw-off strainer

		mit "Power" Hoops	SNARE DRUM WITH POWER HOOPS	Caisse Claire avec Cereles "Power"	CAJA CON ARO "POWER"	Rullante con Cerchi "Power"
3 1/2	S335	Verchromt	CHROME	Chromé	CROMADO	Cromato
	S435	Verchromt	CHROME	Chromé	CROMADO	Cromato
	MS335	Alhorn	MAPLE	Érable	ARCE	Acero
	MS435	Alhorn	MAPLE	Érable	ARCE	Acero
	B335	Messing	BRASS	Laiton	MÉTALICA	Ottone
	B435	Messing	BRASS	Laiton	MÉTALICA	Ottone
4 1/2	S345	Verchromt	CHROME	Chromé	CROMADO	Cromato
	MS345	Alhorn	MAPLE	Érable	ARCE	Acero

		mit "Die-Cast" Hoops	SNARE DRUM WITH DIE-CAST HOOPS	Caisse Claire avec Cereles Moulés	CAJA CON ARO "DIE-CAST"	Rullante con Cerchi "Die-Cast"
5	S450DH	Verchromt	CHROME	Chromé	CROMADO	Cromato
	MS450DH	Alhorn	MAPLE	Érable	ARCE	Acero
	B450DH	Messing	BRASS	Laiton	MÉTALICA	Ottone
6 1/2	S465DH	Verchromt	CHROME	Chromé	CROMADO	Cromato
	MS465DH	Alhorn	MAPLE	Érable	ARCE	Acero
	BS465DH	Birke	BIRCH	Bouleau	ABEDUL	Betulla
	BS465	mit "Power" Hoop	with Power Hoops	avec Cereles "Power"	CON ARO "POWER"	con Cerchi "Power"
	B465DH	Messing	BRASS	Laiton	MÉTALICA	Ottone

		mit "Die-Cast" Hoops	SNARE DRUM WITH DIE-CAST HOOPS	Caisse Claire avec Cereles Moulés	CAJA CON ARO "DIE-CAST"	Rullante con Cerchi "Die-Cast"
8	S480DH	Verchromt	CHROME	Chromé	CROMADO	Cromato
	S480	mit "Power" Hoop	with Power Hoops	avec Cereles "Power"	CON ARO "POWER"	con Cerchi "Power"
	MS480DH	Alhorn	MAPLE	Érable	ARCE	Acero
	BS480DH	Birke	BIRCH	Bouleau	ABEDUL	Betulla
	B480DH	Messing	BRASS	Laiton	MÉTALICA	Ottone
	B480	mit "Power" Hoop	with Power Hoops	avec Cereles "Power"	CON ARO "POWER"	con Cerchi "Power"

3 1/2

PICCOLO



S435-14"
*S335-13"

MS435-14"
*MS335-13"

B335-13"

B435-14"

4 1/2
5



* S450DH-5"
S345-4 1/2"

MS345-4 1/2"

MS450DH-5"

B450DH

6 1/2



S465DH

MS465DH

BS465DH-Die Cast Hoops
*BS465-Power Hoops

B465DH

8



MS480DH

BS480DH

S480DH-Die Cast Hoops
*S480-Power Hoops

B480DH-Die Cast Hoops
*B480-Power Hoops

*Not shown

SOportes TIPO RACKS SYSTEMES
RMS
RACKMOUNT
SYSTEMS
 RACK-HALTER-SYSTEME
 RACK Sistemi Rack



RMS8000

- RMS700 Basic Single Straight Rack
- RMS7200 Deluxe Double Straight Rack with Sides
- RMS800 Basic Single Curved Rack
- RMS8000 Basic Double Curved Rack
- RMS8200 Deluxe Double Curved Rack with Sides



RMS 700 Basic Single Straight Rack



RMS8200 Deluxe Double Curved Rack with Sides



RMS700E Side Rail Extension

*Cymbals, drums, cymbal arms and snare drum basket not included with rack sets

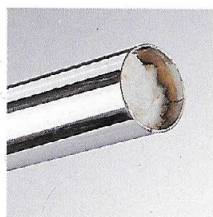

No resonance tube construction

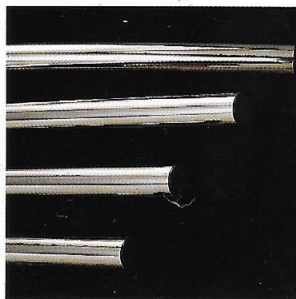

- LCPP Long Curved Pipe (1250 mm/50")
- LSPP Long Straight Pipe (1250 mm/50")
- MSPP Medium Straight Pipe (1000 mm/40")
- SSPP Short Straight Pipe (710 mm/28 1/2")

SOPORTES DE CAJA

Reggiriulanti SNARE

SNARE STANDS

STÄNDER Supports de Caisse Claire

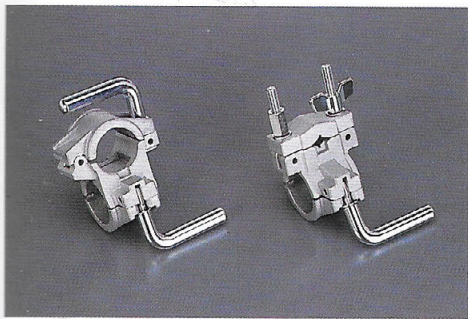

TCLP "T" Clamp

ACLP Accessory Clamp

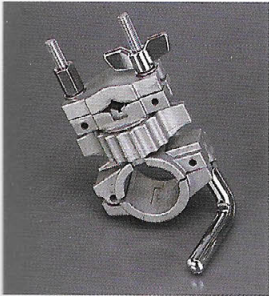

RCLP Rotating Clamp

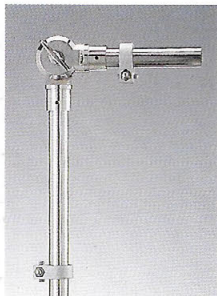

TH66 Tom Arm

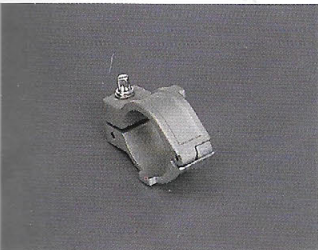

BAML Break away memory clamp

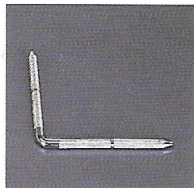

TH61 "L" ROD



RFT Foot

CAP Top Cap

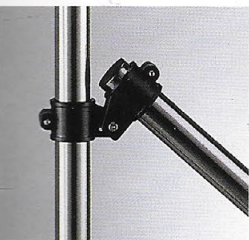

LCLP Leg Clamp

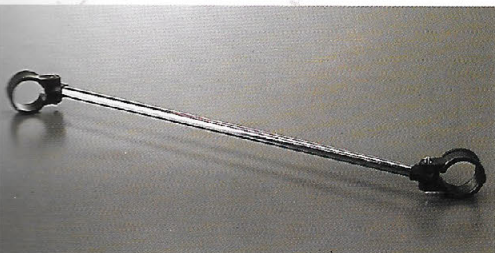

SPT Leg Rod with Connector



Nylon ball socket with "Pro-Lok" lever

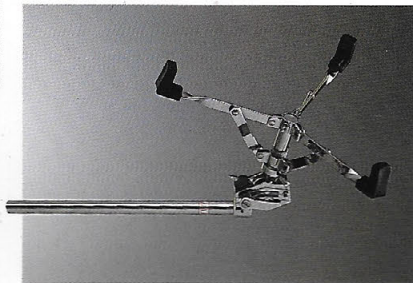

S71 Rackmount Snare Basket



S700

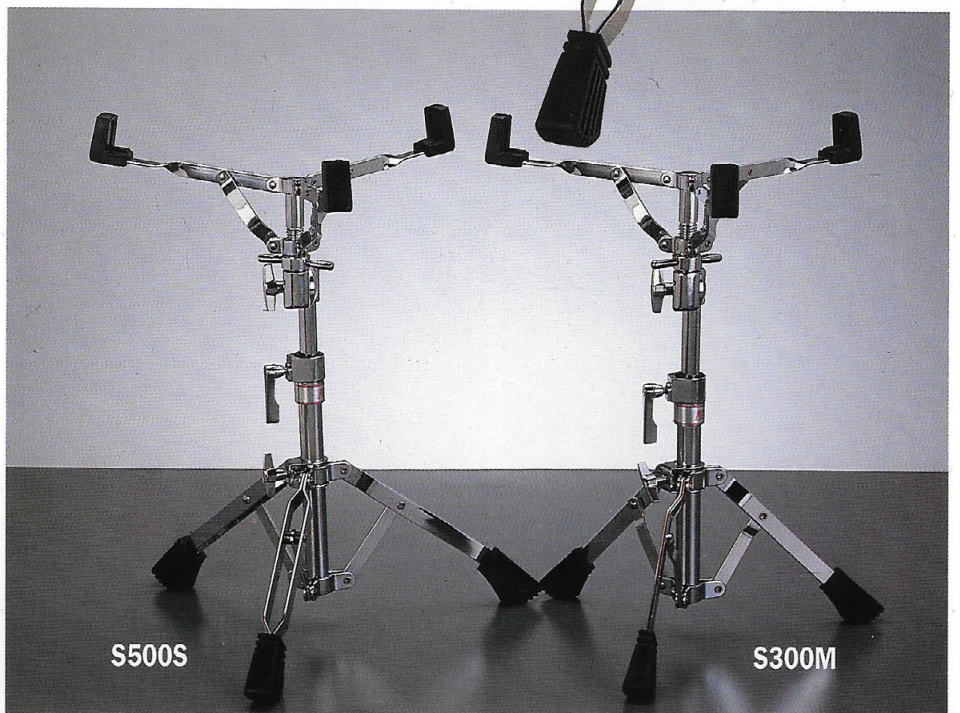

S500S

S300M

PEDALES DE BOMBO

Pédales au Pied

FOOT PEDALS

Pedali

FUßMASCHINEN

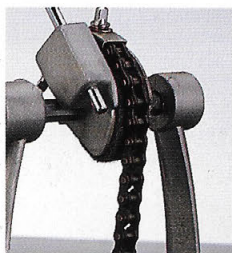

Mini links for fluid, smooth action



Spring adjustment

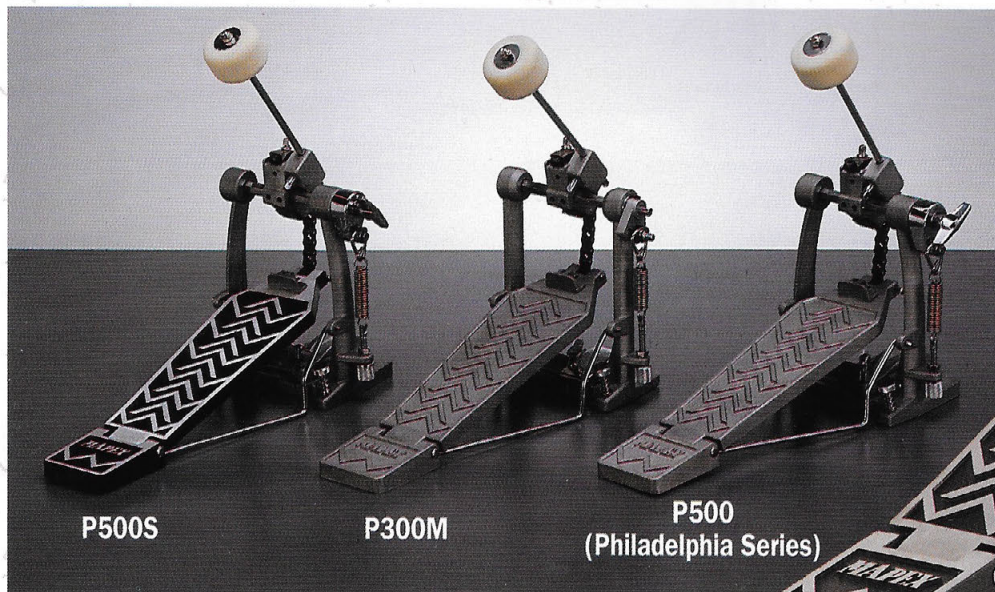

P500S

P300M

P500
(Philadelphia Series)

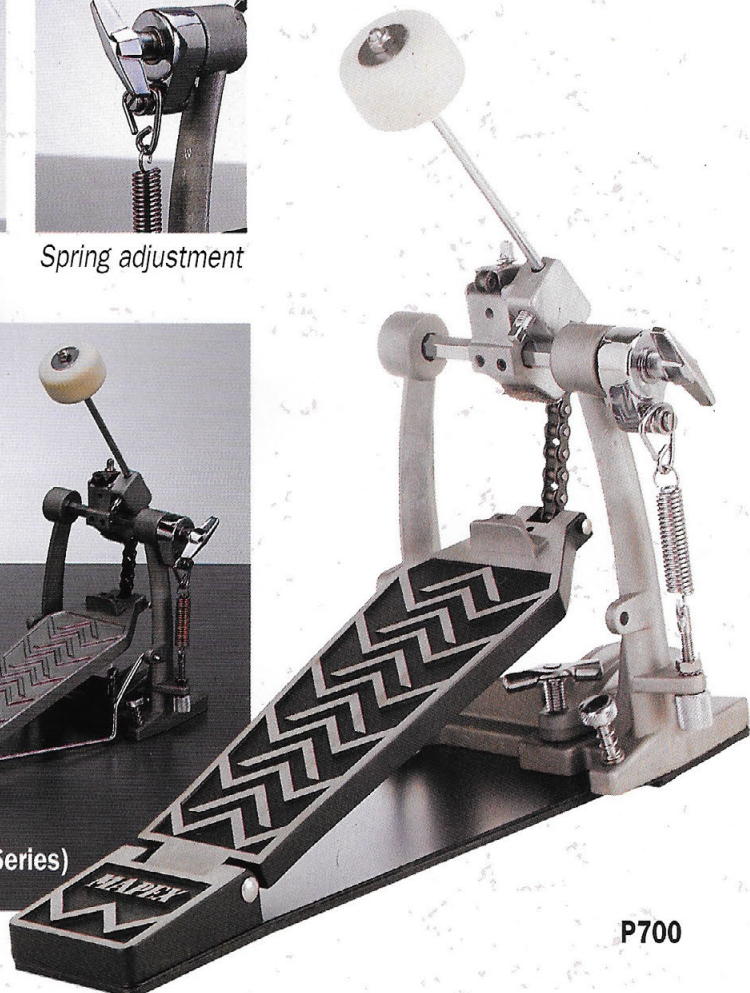

P700

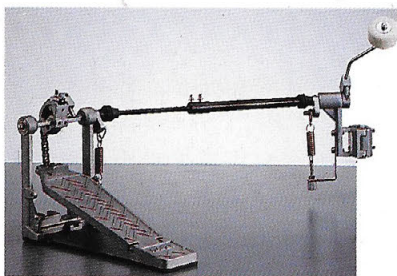

P790 Slave Unit

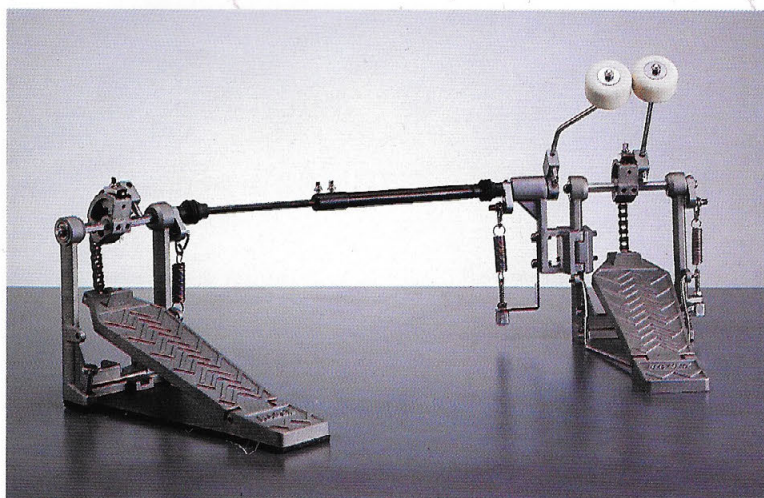

P800 Twin Pedal

HI-HAT STANDS

MIT KETTEN FUßMASCHINE

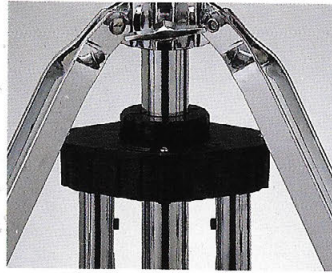

Patented tension adjustment

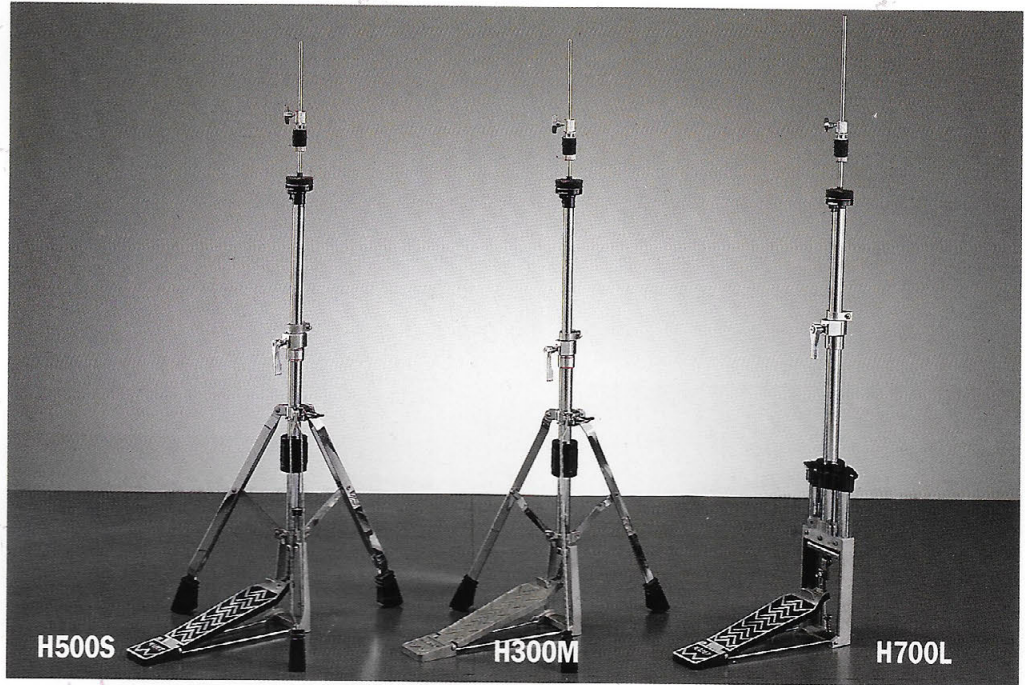

H500S

H300M

H700L

H700



H300M	<i>Einstrebig</i>	SINGLE-BRACED LEGS	Pieds Simple Embase	PERFIL SENCILLO	<i>Gambe A Stelo Singolo</i>
H500S	<i>Dopplestrebig</i>	DOUBLE-BRACED LEGS	Pieds Double Embase	DOBLE PERFIL	<i>Gambe A Doppio Stelo</i>
H700	<i>Doppelt Justierbare Federn</i>	DOUBLE SPRING ADJUSTABLE TENSION	Double Ressort Adjustable	MUELLES DE AJUSTE DOBLE	<i>Doppie Molle Regolabili</i>
H700L	<i>Hi Hat Legless</i>	LEGLESS	Sans Pieds	MODELO SIN PATAS REMOTO	<i>Modello Senza Gambe</i>
CH71	<i>Geschlossene Version</i>	CLOSED MODEL	Fermé	CHARLES CERRADO	<i>Modello Chiuso</i>



No-creep spurs



CH71 Closed Hi-Hat

BECKENSTÄNDER

SOPORTES DE PLATOS Supports de

Cymbale Riggipiatti

CYMBAL STANDS

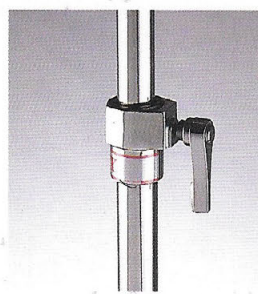

"Pro-Lok" adjustment lever

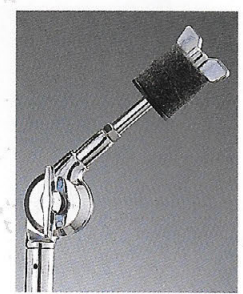

Cymbal tilter



B700

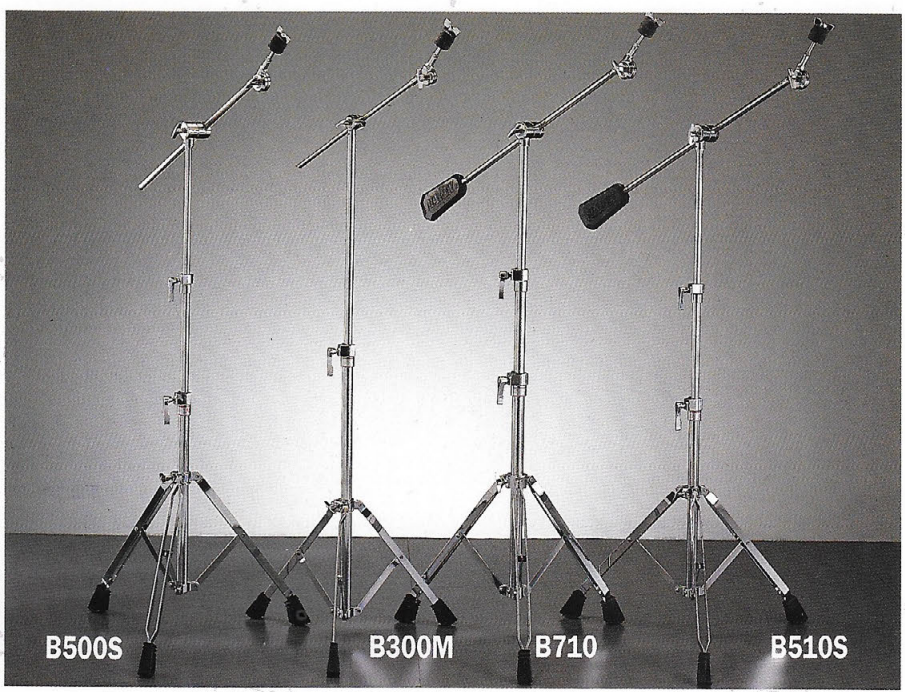

B500S

B300M

B710

B510S

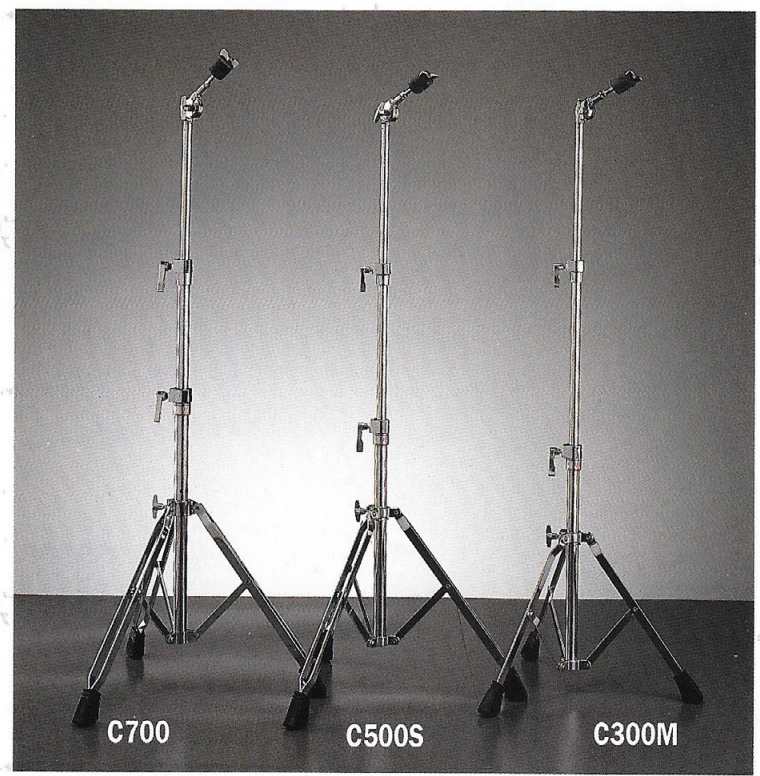

C700

C500S

C300M

HERRAJES

HARDWARE

Pieces Detachées

ZUBEHÖR

Accessori

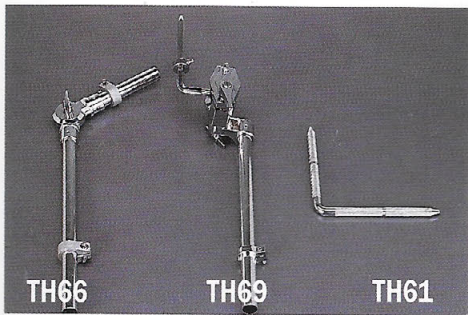

TH66

TH69

TH61



B71

B72

B73

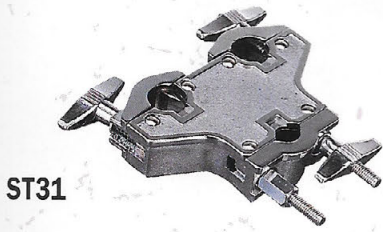

ST31

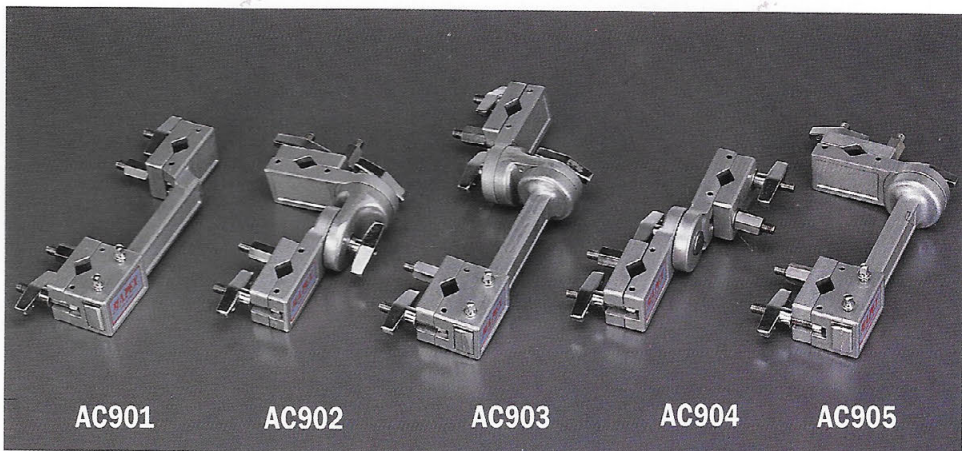

AC901

AC902

AC903

AC904

AC905

VENUS HARDWARE

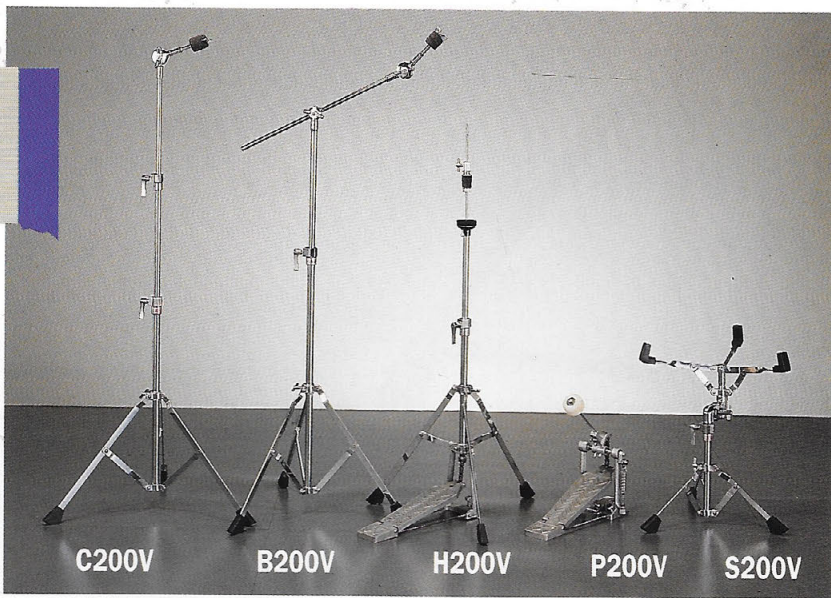

C200V

B200V

H200V

P200V

S200V

Saggiolini

ASIENOS

THRONES

Sieges DRUMMERSITZE



T710

T700

T500S

T300M

MAPEX®



DRUM WEAR



- MTJ Tour Jacket
- MTS T-Shirt
- MTT Terry Cloth Towel
- MSB Stick Bag



MAPEX®

MAPEX®