

# DRUMS & HARDWARE 2008

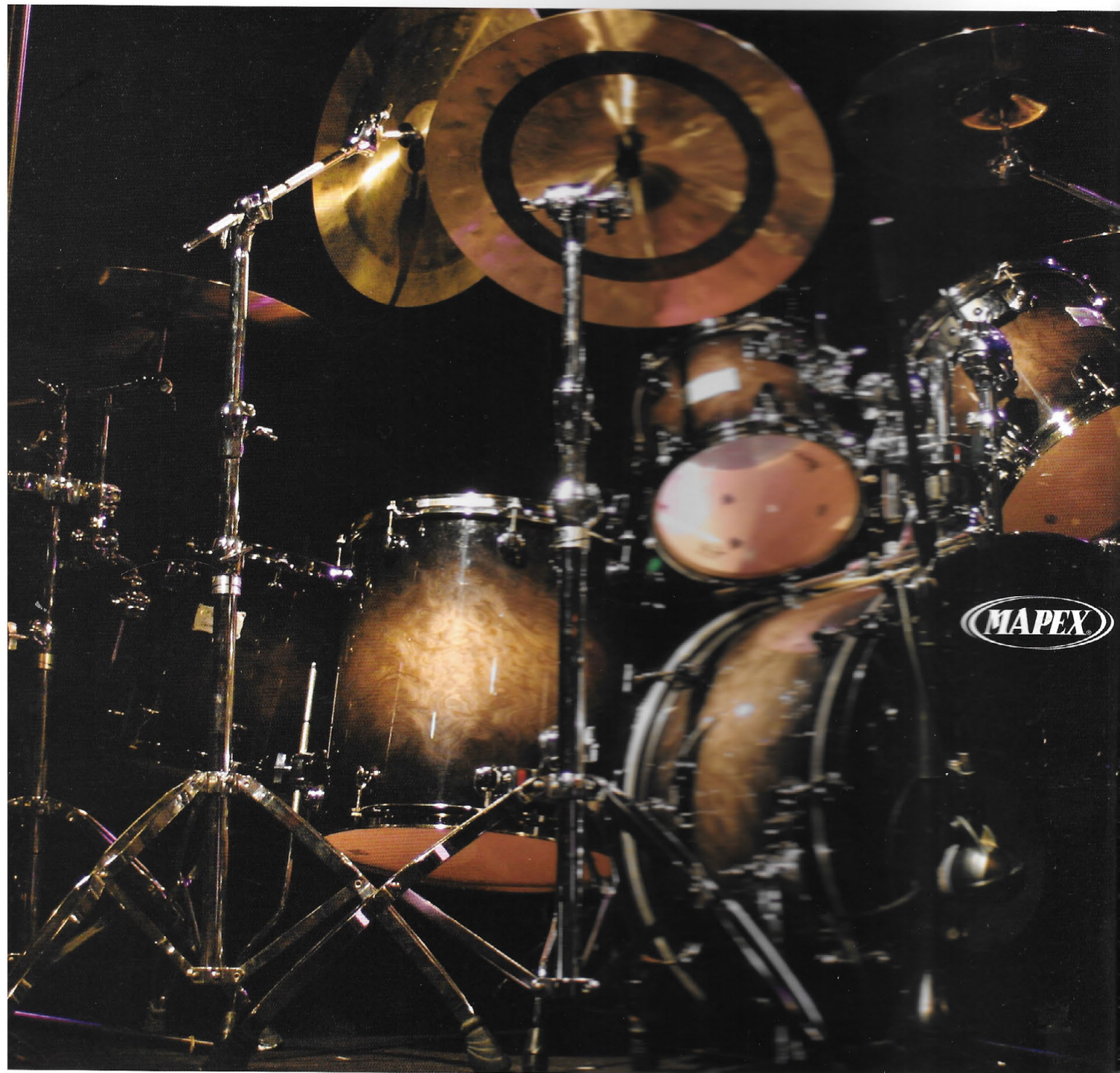

MAPEXDRUMS.COM



# EVERY DAY,

hundreds of people worldwide are dedicated to making certain every Mapex product delivers superior sound and extraordinary functionality, which will result in your having the best possible playing experience.

All Mapex products are hand built and hand assembled by the artisans at our wholly owned factory in Tianjin, China. The people at Mapex have earned a distinguished reputation for designing, engineering and building the highest quality acoustic drums. In fact, Mapex is one of the only companies of its kind to have achieved ISO9001 certification — the world's rigorous standard for manufacturing excellence.

Building the highest quality product initially depends on the expertise of those that select the raw materials — in particular, the wood. This is why the Mapex Professional Wood Grading Team selects only the finest raw materials from which to craft our drums.

Premium grade hardwoods like maple, walnut, birch and basswood are hand-selected from worldwide sources and are then matched by skilled experts to ensure that every drum Mapex produces carries with it the signature tonal and resonant properties that define the distinctive Mapex sound.

Mapex not only wants you to sound your best, you need to look great too. On all of our painted drums, Mapex finish experts hand apply an eight-coat, hand-rubbed, high-gloss lacquer to each shell. Mapex finishes are durable, easy to maintain and will help make you the envy of your drumming community.

The craftsmen at Mapex apply the same high standard of quality across the entire family of products. Every Mapex drum, regardless of price, is built to exacting specifications. Mapex has created a working environment that encourages growth, spirit and dedication to craftsmanship. The people that make Mapex drums are the best at what they do and they take pride in their ability to do it.

The result is a drum that you will take to the stage or studio with complete confidence that your style and creativity will not only be perfectly reproduced, but enhanced. With Mapex your talent and personality will be faithfully delivered, whether you're playing to a crowd of twenty or twenty-thousand. You'll ultimately take as much pride in owning a Mapex drum as the expert builders did when it was created.



MAPEXDRUMS.COM

Will Calhoun  
Living Colour

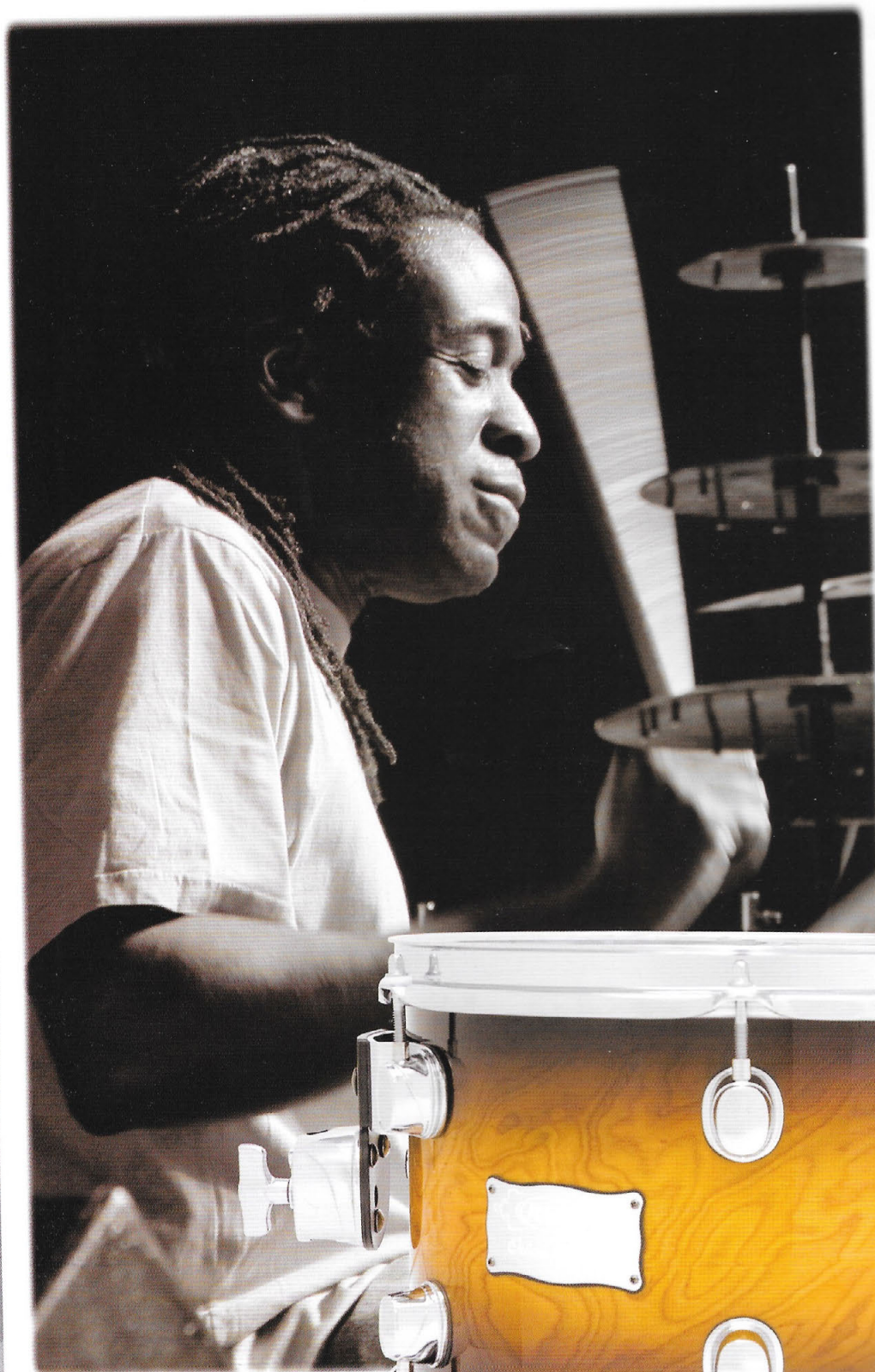

Shell Construction: 7-ply, 6 maple interior, 1 burl maple exterior  
Shell Thickness: 6.1mm tom toms and snares, 7.5mm bass drums

# ORION

If you were asked to describe the perfect drum, would you mention beautiful wood grain with a deep, hand rubbed finish? Thin, responsive shells that deliver precise tone and perfect resonance?

If this is your idea of the perfect drum, then the Mapex Orion Series should get your attention. Also available by component, you are assured that your Orion Series drum set will fit perfectly and be exactly what you've always wanted.



Five-piece **Custom Configured** Orion in the new **Butter Burst** finish.  
22x18 bass drum, 10x8, 12x9 tom toms, 14x14 floor tom, 14x5.5 snare drum

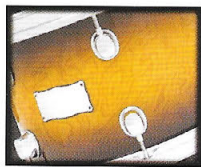

**NEW** Butter Burst (UB)

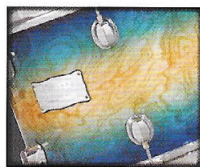

Teal Burst (TU)

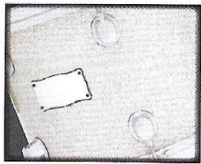

**NEW** Crystal Krush (KT)

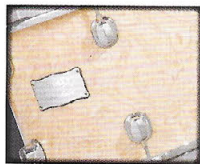

Antique Ivory (AI)

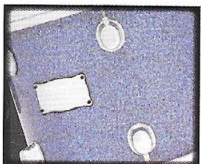

**NEW** Cosmic Krush (KM)

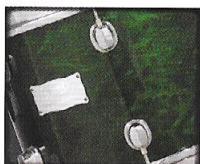

Transparent Emerald Green (EG)

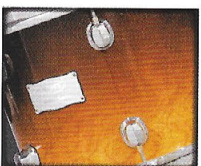

Cinnamon Fade (FS)

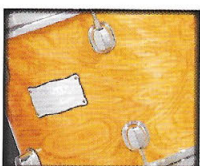

Gloss Natural (NL)

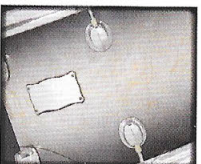

Blue Mist Burst (TN)

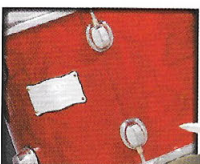

Transparent Red (TR)



Wine Burl Burst (TY)



Coffee Burst (TO)

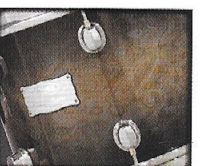

Ebony Burst (TK)

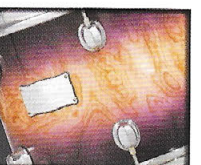

**4** Imperial Burst (TL)

**FINISHES**

Five-piece **Custom Configured Orion** in the **Wine Burl Burst** finish. 22x20 bass drum, 12x9 tom tom, 14x12 and 16x14 floor toms, 14x5.5 snare drum.



Some items and/or finishes may only be available via special order. Consult your retailer for details.



An exquisite exterior burl veneer sets this limited edition apart from anything else you'll ever find. Due to the unique nature of this product, its availability will be highly restricted. If you've been waiting for the ultimate combination of unique beauty and incredible performance, your time has come. This is your drum set.

This limited edition is only available in six-piece component packs, including a 22x18 bass drum, 10x8 and 12x9 tom toms, 14x14 and 16x16 floor toms and a matching 14x5.5 snare drum, all featuring all-maple Orion shell construction and luxurious black chrome hardware and a classic, white coated front bass drum head.

Handmade in Italy, the remarkably figured exterior ply is formed together with six North American maple plies for an ultra-thin, ultra-resonant shell that's built to be enjoyed for generations.

Model number TM628SBPHNL

Orion Special Edition in the new **Gloss Nature** finish in exotic **Chocolate Burl** veneer

[TM628SBPHNL] 22 x 18 bass drum, 10 x 8 and 12 x 9 tom toms, 14 x 14 and 16 x 16 floor toms, 14 x 5.5 snare drum, show with the following hardware: TS960A combination cymbal and tom stand, (2) B950A Boom Stands, H950A hi-hat stand, P950A Pedal, S950A Snare Stand.

CONFIGURATIONS

Configuration	Bass Drum	Tom Toms	Floor Toms	Snare Drum	Tom Holder	Tom Stand	Boom Stand	Cymbal Stand	Snare Stand	Hi-Hat Stand	Pedal
Studio BM6225*	22 x 18	10 x 8 12 x 9 14 x 11 16 x 13		14 x 5.5		TS960A (x2) TS950A			S950A	H950A	P950A
Fusion BM5225*	22 x 18	10 x 8 12 x 9 14 x 11		14 x 5.5	TH685	TS960A	B950A		S950A	H950A	P950A
Standard BM5255*	22 x 18	12 x 9 13 x 10	16 x 16	14 x 5.5	TH685		B950A (x2)		S950A	H950A	P950A

Orion Series components are shipped with our most popular chrome finish, but can also be special ordered with black chrome or gold plated hardware.

Gold\*(GA)

Black\*(BA)

Chrome\*(CA)



The spectacular burlwood outer ply adds an exotic touch of luxury, while the eight coat hand applied lacquer finishes result in a deep, high gloss shine.

Orion drums come equipped with Remo® Ambassador™ heads.

All Orion toms feature the Isolated Tom Mount System that allows the shell to vibrate freely and maximizes projection and resonance.



COMPONENTS

Bass Drums	
BMB1814	18 x 14
BMB1816	18 x 16
BMB2014	20 x 14
BMB2016	20 x 16
BMB2018	20 x 18
BMB2216	22 x 16
BMB2218	22 x 18
BMB2218A	22 x 18
BMB2418	24 x 18
BMB2420	24 x 20
BMB2220A	22 x 20

Tom Toms	
BMT807	8 x 7
BMT808	8 x 8
BMT1007	10 x 7
BMT1008	10 x 8
BMT1009	10 x 9
BMT1207	12 x 7
BMT1208	12 x 8
BMT1209	12 x 9
BMT1210	12 x 10
BMT1307	13 x 7
BMT1309	13 x 9
BMT1310	13 x 10
BMT1311	13 x 11
BMT1410	14 x 10
BMT1411	14 x 11
BMT1412	14 x 12
BMT1512	15 x 12
BMT1513	15 x 13
BMT1613	16 x 13
BMT1614	16 x 14

Floor Toms	
BMF1411	14 x 11
BMF1412	14 x 12
BMF1414	14 x 14
BMF1513	15 x 13
BMF1515	15 x 15
BMF1613	16 x 13
BMF1614	16 x 14
BMF1616	16 x 16
BMF1816	18 x 16

Snare Drums	
BMS2550	12 x 5.5
BMS3600	13 x 6
BMS3700	13 x 7
BMS4550	14 x 5.5
BMS4650	14 x 6.5
BMS4700	14 x 7

BMB2218A & BMB2220A  
Without tom mount

Seven-piece Custom Configured Orion in the **Ebony Burst** finish with **Black Chrome** hardware. 22x18 bass drum, 10x8, 12x9, 13x10 tom toms, 14x14 and 16x16 floor toms, 14x5.5 snare drum.

Chris Adler  
Lamb Of God

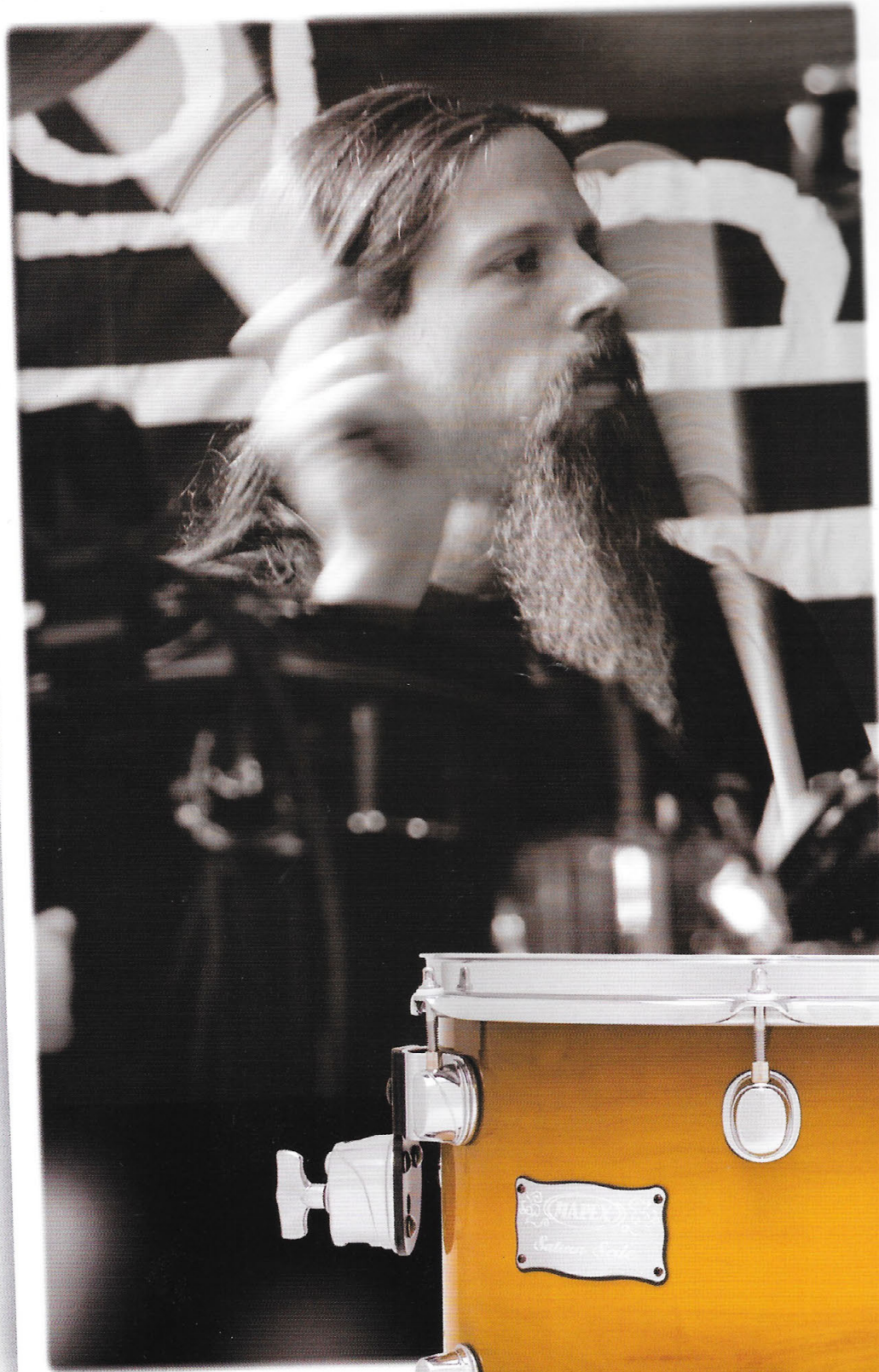

Shell Construction: 6-ply 4 maple exterior, 2 walnut interior  
Shell Thickness: 5.1mm tom toms and snares, 7.5mm bass drums



# SATURN

Saturn is ideal for any studio application and has been extensively tested in critical live situations. The Saturn is available in a wide range of configurations and individual components to satisfy any set-up.

The incredibly thin Saturn shell is made from four exterior plies of maple and two interior plies of walnut. The result is an instrument with superior resonance and tuning range and deep, rich tone that can only be achieved by a Saturn.



The new Saturn **Studioease Configuration** in the new **Sienna Burst** finish.

[SW628SU] 22x18 bass drum, 10x8 and 12x9 tom toms, 14x14 and 16x16 floor toms, 14x5.5 snare drum. Available as a shell pack or with the following hardware: TH682 tom holder, (2) B750A boom stands, S750A snare stand, H750A hi-hat stand, P750A pedal.

# SATURN

Saturn toms come with Remo® Emperor™ heads.

Beginning in 2008, Saturn drums are available with black chrome hardware.

All Saturn toms feature Mapex's exclusive Isolated Tom Mount System for maximum shell projection and resonance.

Saturn floor toms legs are shock loaded to absorb the impact of fierce playing.

## Seven-Piece Custom Configured Saturn with add-on tom in the new **Blue Galaxy Sparkle Burst** finish.

22x18 bass drum, 8x7, 10x8 and 12x9 tom toms, 14x14 and 16x16 floor toms, 14x5.5 snare drum. Shown with the following hardware: TS960A tom stand, TS550A tom stand, (2) B550A boom stands, S750A snare stand, H750A hi-hat stand, P750A pedal.



**The Saturn Crossover 22 Configuration in the Root Beer Burst lacquer finish.**

[SW5286U] 22x16 bass drum, 12x9 tom tom, 14x14 and 16x16 floor toms, 14x5.5 snare drum. Includes the following hardware: TS960A tom stand, (2) B750A boom stands, S750A snare stand, H750A hi-hat stand, P750A pedal.

Saturn drums are finished with eight hand-applied coats of high-gloss lacquer for a deep and durable shine.



Saturn drum sets come with heavy-duty Mapex 750A Series double braced hardware.

**The Saturn Plus Bass Rock 24 Configuration with the Plus Bass 24 Add-On Pack in the new Gloss Natural finish.**

[SW4496U] 24x20 bass drum, 12x9 tom tom, 16x16 floor tom, 14x7 snare drum. Includes the following hardware: TS960A tom stand, (2) B750A boom stands, S750A snare stand, H750A hi-hat stand, P750A pedal. Add-On pack [SWPK408U] comes with 24x20 bass drum, 10x8 tom tom, 18x16 floor tom, P750A pedal, TS960A tom stand, AC906 multi-clamp.

# SATURN

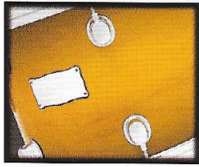

**NEW** Sienna Burst  
(IT)

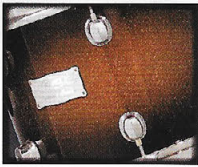

Root Beer Burst  
(TX)

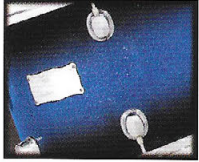

**NEW** Blue Galaxy Sparkle  
Burst  
(TT)

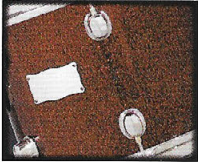

Black Cherry Sparkle  
(YS)

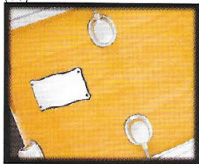

**NEW** Gloss Natural  
(NL)

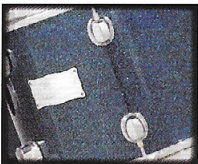

Electric Blue Sparkle  
(EU)

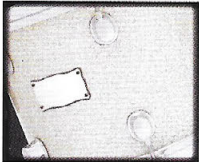

**NEW** Crystal Krush  
(KT)



Mango Burst  
(TM)

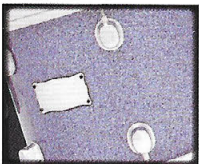

**NEW** Cosmic Krush  
(KM)

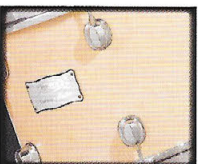

Antique Ivory  
(AI)

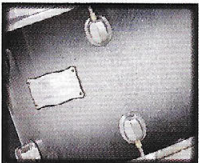

Galaxy Burst  
(TJ)

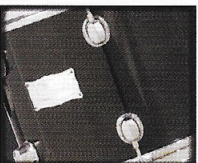

Transparent Black  
(TB)

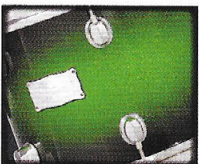

Green Apple Burst  
(TG)



Transparent Cherry Red  
(CY)

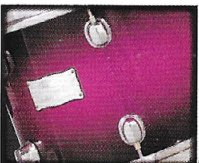

Electric Berry Burst  
(TH)

The Saturn **Fusionease Configuration** in the **Green Apple Burst** lacquer finish.

[SW5245U] 22x18 bass drum, 10x8 and 12x9 tom toms, 14x14 floor tom, 14x5.5 snare drum. Includes the following hardware: TH682 tom holder, (2) B750A boom stands, S750A snare stand, H750A hi-hat stand, P750A pedal.

FINISHES

Saturn bass drums come with off-the-shell mounted telescopic legs.

Cushioned, die cast bass drum claws add style and precise tuning.



CONFIGURATIONS

Configuration	Bass Drum	Tom Toms	Floor Toms	Snare Drum	Tom Holder	Tom Stand	Boom Stand	Cymbal Stand	Snare Stand	Hi-Hat Stand	Pedal	Multi-Clamp
<b>7-PIECE DRUM SETS</b>												
Plus Bass Fusion Pop 22 SW7287U	22 x 20	8 x 7 10 x 8 12 x 9	14 x 12 16 x 14	14 x 5.5		TS960A TS550A	B750A (x2)		S750A	H750A	P750A	
<b>6-PIECE DRUM SETS</b>												
<b>NEW</b> Studioease SW6285U	22 x 18	10 x 8 12 x 9	14 x 14 16 x 16	14 x 5.5	TH682		B750A (x2)		S750A	H750A	P750A	
Studio SW6225U	22 x 18	10 x 8 12 x 9 14 x 11 16 x 13		14 x 5.5	TH682	TS550A	B750A (x2)		S750A	H750A	P750A	
<b>5-PIECE DRUM SETS</b>												
Crossover 22 SW5286U	22 x 16	12 x 9	14 x 14 16 x 16	14 x 5.5		TS960A	B750A (x2)		S750A	H750A	P750A	
Standard SW5255U	22 x 18	12 x 9 13 x 10	16 x 16	14 x 5.5	TH682		B750A (x2)		S750A	H750A	P750A	
Fusionease SW5245U	22 x 18	10 x 8 12 x 9	14 x 14	14 x 5.5	TH682		B750A (x2)		S750A	H750A	P750A	
Fusion SW5225U	22 x 18	10 x 8 12 x 9 14 x 11		14 x 5.5	TH682 TH684		B750A (x2)		S750A	H750A	P750A	AC910
Jazz SW5045U	20 x 18	10 x 8 12 x 9	14 x 14	14 x 5.5	TH682		B750A (x2)		S750A	H750A	P750A	
<b>4-PIECE DRUM SETS</b>												
Plus Bass Rock 24 SW496U	24 x 20	12 x 9	16 x 16	14 x 7		TS960A	B750A (x2)		S750A	H750A	P750A	
Manhattan SW4815U	18 x 14	12 x 8	14 x 14	14 x 5.5	TH686		B750A	C750A	S350A	H750A	P750A	AC909
<b>SHELL PACKS</b>												
<b>NEW</b> Studioease Shell Pack <b>NEW</b> SW628SU(with mount)	22 x 18	10 x 8 12 x 9	14 x 14 16 x 16	14 x 5.5	TH682							
Fusionease Shell Pack SW524SU	22 x 18	10 x 8 12 x 9	14 x 14	14 x 5.5	TH682							
<b>ADD-ON PACK</b>												
Plus Bass 24 Add-On SWPK408U	24 x 20	10 x 8	18 x 16			TS960A					P750A	AC906

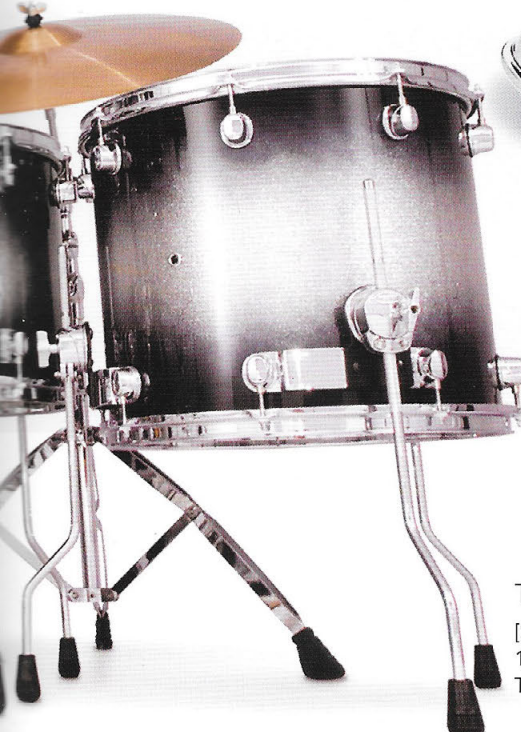

The Saturn Series is available with chrome or black chrome hardware. See your retailer for details.

COMPONENTS

Bass Drums	
SWB1814U	18 x 14
SWB1816U	18 x 16
SWB2014U	20 x 14
SWB2016U	20 x 16
SWB2018U	20 x 18
SWB2216U	22 x 16
SWB2216UA	22 x 16
SWB2218U	22 x 18
SWB2218UA	22 x 18
SWB2220UA	22 x 20
SWB2418U	24 x 18
SWB2420U	24 x 20
Tom Toms	
SWT807U	8 x 7
SWT808U	8 x 8
SWT1055U	10 x 5.5
SWT1007U	10 x 7
SWT1008U	10 x 8
SWT1009U	10 x 9
SWT1206U	12 x 6
SWT1208U	12 x 8
SWT1209U	12 x 9
SWT1210U	12 x 10
SWT1310U	13 x 10
SWT1311U	13 x 11
SWT1407U	14 x 7
SWT1410U	14 x 10
SWT1411U	14 x 11
SWT1412U	14 x 12
SWT1512U	15 x 12
SWT1513U	15 x 13
SWT1613U	16 x 13
SWT1614U	16 x 14

Floor Toms	
SWF1412U	14 x 12
SWF1414U	14 x 14
SWF1513U	15 x 13
SWF1515U	15 x 15
SWF1614U	16 x 14
SWF1616U	16 x 16
SWF1816U	18 x 16
Snare Drums	
SWS3550U	13 x 5.5
SWS4550U	14 x 5.5
SWS4650U	14 x 6.5
SWS4700U	14 x 7

The Saturn Plus Bass Fusion Pop 22 Configuration in the Galaxy Burst finish. [SW7287U] 22x20 bass drum, 8x7, 10x8 and 12x9 tom toms, 14x12 and 16x14 floor toms, 14x5.5 snare drum. Available as a shell pack or with the following hardware: TS960A and TS550A tom stands, (2) B750A boom stands, S750A snare stand, H750A hi-hat stand, P750A pedal.

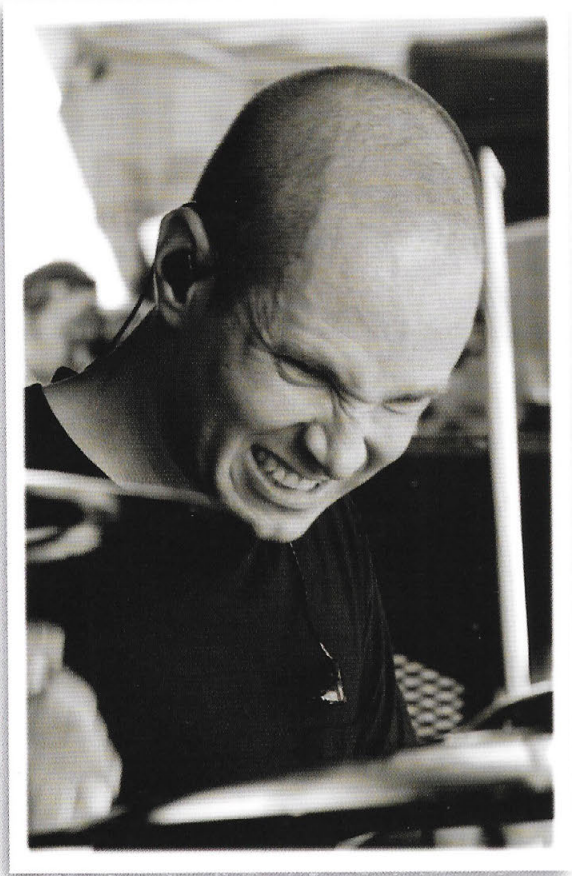

**Chris Pennie**  
Coheed and Cambria

It's easy to understand why the Pro M is Mapex's fastest growing series. Its thin maple shells, professional appointments and luxurious finishes are within reach of every serious player.

The Pro M features Mapex's exclusive Isolated Tom Mount System, heavy-duty, double braced hardware and a huge selection of gorgeous lacquer finishes or high quality Delmar® wrapped finishes.

When you're getting serious about a drum set, you'll find that the Pro M cuts no corners.



**Pro M Rock configuration in Boston Pewter finish**

[PM5466U] 24x18 bass drum, 13x10 tom tom, 16x16, 18x16 floor toms, 14x6.5 snare drum includes the following hardware: TS960A combination cymbal and tom stand, (2) B550A boom stands, S550A snare stand, H750A hi-hat stand, P750A Pedal

**Shell Construction:** 7-ply, all maple

**Shell Thickness:** 5.8mm tom toms and snares, 7.2mm bass drums

# PRO M



The new Pro M **Studioease Configuration** in the new **Sapphire Fade** finish.

[PM6285U] 22x18 bass drum, 10x8 and 12x9 tom toms, 14x14 and 16x16 floor toms, 14x5.5 snare drum. Includes the following hardware: TH675 tom holder, B550A boom stand, C550A cymbal stand, S550A snare stand, H750A hi-hat stand, P750A pedal.

# FINISHES



**NEW** Sienna Burst  
(IT)



Gloss Natural  
(NL)



**NEW** Sapphire Fade  
(SI)



Vanilla Cream Pearl  
(VP)

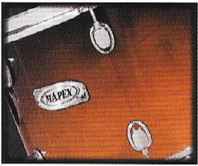

Red Wood Fade  
(OF)



Black Chrome Pearl  
(KP)



Boston Pewter Fade  
(PF)



Liquid Blue Pearl  
(LP)



Bermuda Sparkle  
(OS)

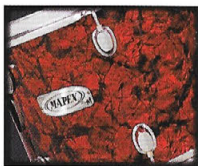

Ruby Red Pearl  
(RP)



Platinum Sparkle  
(SS)



Caramel Fade  
(YL)



Transparent Midnight Black  
(MB)

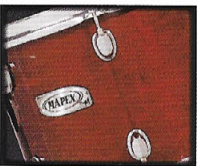

Transparent Cherry Red  
(CY)

## The Pro M Crossover 22 Configuration in the Ruby Red Pearl finish.

[PM5286U] 22x18 bass drum, 12x9 tom tom, 14x14 and 16x16 floor toms, 14x5.5 snare drum. Includes the following hardware: TS960A tom stand, (2) B550A boom stands, S550A snare stand, H750A hi-hat stand, P750A pedal.



Pro M covered finishes are supplied by Delmar® for the ultimate in quality, style and protection.

All Pro M toms are equipped with Mapex's Exclusive Isolated Tom Mount system for maximum shell projection and resonance.

The Pro M's all maple shells are finished with eight hand-applied coats of high gloss lacquer for a deep and durable shine.



## The Pro M Classic Configuration with the Plus Bass 22 Add-on Pack in the new Sienna Burst finish.

[PM4266U] 22x20 bass drum, 12x9 tom tom, 16x16 floor tom, 14x7 snare drum. Includes the following hardware: TS960A tom stand, (2) B550A boom stands, S550A snare stand, H750A hi-hat stand, P750A pedal. Add-on Pack [PMPK208U] includes 22x20 bass drum, 10x8 tom tom, 18x16 floor tom, P750A pedal, TS960A tom stand, AC906 multi-clamp



Configuration	Bass Drum	Tom Toms	Floor Toms	Snare Drums	Tom Holder	Tom Stand	Boom Stand	Cymbal Stand	Snare Stand	Hi-Hat Stand	Pedal	Multi-Clamp
<b>7-PIECE DRUM SETS</b>												
Plus Bass Fusion Pop 22 PM7287U	22 x 20	8 x 7 10 x 8 12 x 9	14 x 12 16 x 14	14 x 5.5		TS960A TS550A	B550A (x2)		S550A	H750A	P750A	
<b>6-PIECE DRUM SETS</b>												
<b>NEW</b> Studioease PM6285U	22 x 18	10 x 8 12 x 9	14x14 16x16	14 x 5.5	TH675		B550A	C550A	S550A	H750A	P750A	
Studio PM6225U	22 x 18	10 x 8 12 x 9 14 x 11 16 x 13		14 x 5.5	TH675	TS550A	B550A	C550A	S550A	H750A	P750A	
<b>5-PIECE DRUM SETS</b>												
Rock PM5466U	24 x 18	13 x 10	16 x 16 18 x 16	14 x 6.5		TS960A	B550A (x2)		S550A	H750A	P750A	
Crossover 22 PM5286U	22 x 18	12 x 9	14 x 14 16 x 16	14 x 5.5		TS960A	B550A (x2)		S550A	H750A	P750A	
Standard PM5255U	22 x 18	12 x 9 13 x 10	16 x 16	14 x 5.5	TH675		B550A	C550A	S550A	H750A	P750A	
Fusionease PM5245U	22 x 18	10 x 8 12 x 9	14 x 14	14 x 5.5	TH675		B550A	C550A	S550A	H750A	P750A	
Fusion PM5225U	22 x 18	10 x 8 12 x 9 14 x 11		14 x 5.5	TH675 TH684		B550A	C550A	S550A	H750A	P750A	AC910
Jazz* PM5045U	20 x 18	10 x 8 12 x 9	14 x 14	14 x 5.5	TH675		B550A	C550A	S550A	H750A	P750A	
<b>4-PIECE DRUM SETS</b>												
Classic PM4266U	22 x 20	12 x 9	16 x 16	14 x 7		TS960A	B550A (x2)		S550A	H750A	P750A	
Manhattan PM4815U	18 x 14	12 x 8	14 x 14	14 x 5.5	TH686		B350A	C350A	S350A	H350A	P750A	AC909
<b>ADD-ON PACK</b>												
Plus Bass 22 Add-On Pack PMPK208U	22 x 20	10 x 8	18 x 16			TS960A					P750A	AC906

\* Jazz configuration also available with 20x16 Bass Drum. See retailer for additional information.

<b>Bass Drums</b>	
PMB1814N	18 x 14
PMB1816N	18 x 16
PMB2016N	20 x 16
PMB2018N	20 x 18
PMB2216N	22 x 16
PMB2218N	22 x 18
PMB2218NA	22 x 18
PMB2220NA	22 x 20
PMB2418N	24 x 18
PMB2420N	24 x 20
<b>Tom Toms</b>	
PMT804N	8 x 4
PMT807N	8 x 7
PMT808N	8 x 8
PMT1055N	10 x 5.5
PMT1007N	10 x 7
PMT1009N	10 x 8
PMT1009N	10 x 9
PMT1208N	12 x 6
PMT1208N	12 x 8
PMT1209N	12 x 9
PMT1210N	12 x 10
PMT1309N	13 x 9
PMT1310N	13 x 10
PMT1311N	13 x 11
PMT1407N	14 x 7
PMT1410N	14 x 10
PMT1411N	14 x 11
PMT1412N	14 x 12
PM11608N	16 x 8
PMT1613N	16 x 13
PMT1614N	16 x 14
<b>Floor Toms</b>	
PMF1412N	14 x 12
PMF1414N	14 x 14
PMF1515N	15 x 15
PMF1613N	16 x 13
PMF1614N	16 x 14
PMF1616N	16 x 16
PMF1816N	18 x 16
<b>Snare Drums</b>	
PMS3506U	13 x 5
PMS4556U	14 x 5.5
PMS4656U	14 x 6.5
PMS4706U	14 x 7
PMS4806U	14 x 8

# PRO M



Pro M special edition with new **Exotic Zebra wood Veneer in Transparent Amber Fade Finish.**

[PM6285ZUBA]22x18 bass drum, 10x8 and 12x9 tom toms, 14x14 and 16x16 Floor toms, 14x5.5 snare drum, includes the following hardware: TH675 Tom holder, B550A boom stand, C550A cymbal stand, H750A hi-hat stand, S550A snare stand, P750A Pedal



Mike Novak  
Every Time I Die

M Birch drum sets include a full complement of double braced 550A Series hardware.

Eight coats of hand applied lacquer create a mirror-like finish that accentuates the beautiful, natural wood grain.



The M Birch **Fusionease Configuration** with 8" tom pack in the **Black Forest Sapphire** finish.

[MB5245A] 22x18 bass drum, with 8" tom pack, 10x8, 12x9 tom toms, 14x14 floor tom, 14x5.5 snare drum. Includes the following hardware: TH650, B550A boom stand, C550A cymbal stand, S550A snare stand, H550A hi-hat stand, P550A pedal, with 8" tom pack (8x8, TH684 tom holder and multi-clamp AC910)

Shell Construction: 6-ply, five birch, one exterior maple  
Shell Thickness: 7.2mm

# M BIRCH

Mapex M Birch has established itself as a worldwide favorite. One hundred percent birch shells, a beautiful exterior ply of maple, striking high-gloss transparent lacquer finishes, double braced hardware tom what's not to love?

This year, we've introduced two new colors and two new configurations, giving you an even broader selection with this remarkable drum series.



The new M Birch **Studioease Configuration** with 8" tom pack in the new **Hermosa Fade** finish.

[MB6285A] 22x18 bass drum, 10x8 and 12x9 tom toms, 14x14 and 16x16 floor toms, 14x5.5 snare drum. Includes the following hardware: TH650, B550A boom stand, C550A cymbal stand, S550A snare stand, H550A hi-hat stand, P550A pedal, with 8" tom pack (8x8, TH684 tom holder and multi-clamp AC910)

# M BIRCH



**NEW** Hermosa Fade (HF)



Transparent Sapphire (TS)



**NEW** Transparent Midnight Black (MB)



Black Forest Sapphire (ST)



Black Forest Cherry (BC)



Black Forest Green (BG)



Transparent Cherry Red (CY)



Transparent Emerald Green (EG)

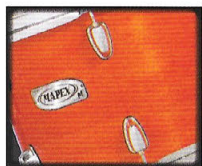

Transparent Honey Amber (HA)

FINISHES

The M Birch **Rock 22 Configuration** with 10" tom pack in the new **Transparent Midnight Black** finish.

[MB4265A] 22x18 bass drum, 12x9 tom toms, 16x16 floor tom, 14x5.5 snare drum. Includes the following hardware: TH650 tom holders, B550A boom stand, C550A cymbal stand, S550A snare stand, H550A hi-hat stand, P550A pedal, with 10" tom pack (10x8, TH684 tom holder and multi-clamp AC910)



M Birch drum sets include a full complement of double braced 550A Series hardware.

Eight coats of hand applied lacquer create a mirror-like finish that accentuates the beautiful, natural wood grain.

The M Birch **Jazz Configuration** with 8" tom pack in the **Transparent Honey Amber** finish.

[MB5045A] 20x18 bass drum, 10x8 and 12x9 tom toms, 14x14 floor tom, 14x5.5 snare drum. Includes the following hardware: TH650, B550A boom stand, C550A cymbal stand, S550A snare stand, H550A hi-hat stand, P550A pedal, with 8x8 tom pack (8x8, TH684 tom holder and multi-clamp AC910)

Configuration	Bass Drum	Tom Toms	Floor Toms	Snare Drum	Tom Holder	Tom Stand	Boom Stand	Cymbal Stand	Snare Stand	Hi-Hat Stand	Pedal	Multi-Clamp
<b>6-PIECE DRUM SETS</b>												
<b>NEW</b> Studioease MB6285A	22 x 18	10 x 8 12 x 9	14 x 14 16 x 16	14 x 5.5	TH650		B550A	C550A	S550A	H550A	P550A	
Studio MB6225A	22 x 18	10 x 8 12 x 9 14 x 11 16 x 13		14 x 5.5	TH650	TSS51A	B550A	C550A	S550A	H550A	P550A	
<b>5-PIECE DRUM SETS</b>												
Crossover 22 MB5285A	22 x 18	12 x 9	14 x 14 16 x 16	14 x 5.5	TH653		B550A	C550A	S550A	H550A	P550A	
Standard MB5255A	22 x 18	12 x 9 13 x 10	16 x 16	14 x 5.5	TH650		B550A	C550A	S550A	H550A	P550A	
Fusionease MB5245A	22 x 18	10 x 8 12 x 9	14 x 14	14 x 5.5	TH650		B550A	C550A	S550A	H550A	P550A	
Fusion MB5225A	22 x 18	10 x 8 12 x 9 14 x 11		14 x 5.5	TH650 TH684		B550A	C550A	S550A	H550A	P550A	AC910
Jazz MB5045A	20 x 18	10 x 8 12 x 9	14 x 14	14 x 5.5	TH650		B550A	C550A	S550A	H550A	P550A	
<b>4-PIECE DRUM SETS</b>												
Rock 24 MB4466A	24 x 18	12 x 9	16 x 16	14 x 6.5		TS961A	B550A (x2)		S550A	H550A	P550A	
<b>NEW</b> Rock 22 MB4265A	22 x 18	12 x 9	16 x 16	14 x 5.5	TH650		B550A	C550A	S550A	H550A	P550A	
<b>ADD-ON PACKS</b>												
<b>GO-LARGE</b> Add-on Pack MBBF2218PK	22 x 18		18 x 16		TH650		B550A				P550A	

<b>Bass Drums</b>	
MBB1814	18 x 14
MBB2016	20 x 16
MBB2018	20 x 18
MBB2216	22 x 16
MBB2218	22 x 18
MBB2218A	22 x 18
MBB2418	24 x 18
<b>Tom Toms</b>	
MBT807	8 x 7
MBT808	8 x 8
MBT1007	10 x 7
MBT1008	10 x 8
MBT1009	10 x 9
MBT1208	12 x 8
MBT1209	12 x 9
MBT1210	12 x 10
MBT1309	13 x 9
MBT1310	13 x 10
MBT1311	13 x 11
MBT1411	14 x 11
MBT1412	14 x 12
MBT1613	16 x 13
MBT1614	16 x 14
<b>Floor Toms</b>	
MBF1414	14 x 14
MBF1616	16 x 16
MBF1816	18 x 16
<b>Snare Drums</b>	
MBS4556	14 x 5.5
MBS4656	14 x 6.5

MBB2218A without tom mount

**"GO LARGE" Bass Drum and Floor Tom Add-On Pack MBBF2218PK**  
 22 x 18 Bass Drum  
 18 x 16 Floor Tom  
 P550A Bass Drum Pedal  
 B550A Boom Stand  
 TH650 Tom Holder

**Standard with the "GO LARGE" Add-on Pack MB5255A + MBBF2218PK | Transparent Cherry Red**  
 (2) 22x18 bass drums, 12x9 tom tom, 13x10 tom tom, 16x16 floor tom, 18x16 floor tom, 14x5.5 snare drum with additional 10x8 Tom Pack, Mapex 550 Series Hardware

**The M Birch Standard Configuration with 10" tom pack in the Transparent Cherry Red finish with the GO LARGE Add-On Pack**

[MB5255A] 22x18 bass drum, 12x9, 13x10 tom toms, 16x16 floor tom, 14x5.5 snare drum. Includes the following hardware: TH650, B550A boom stand, C550A cymbal stand, S550A snare stand, H550A hi-hat stand, P550A pedal, with 10" tom pack. The GO LARGE PACK [MBBF2218PK] includes 22x18 bass drum, 18x16 floor tom, P550A pedal, B550A boom stand, TH650 tom holder



Derrick Frost  
Chiodos



Shell Construction: 9-ply, 8 ply basswood, 1-ply maple exterior  
Shell Thickness: 7.2mm

# VX SERIES

The VX Series features lacquer-finished genuine basswood shells for deep, rich tone with striking visual appeal and close attention to detail.

Unlike other drum sets in its class, the VX includes the Mapex exclusive Isolated Tom Mount System, double braced hardware and a throne.



The VX series **Standard Configuration** in **Transparent Midnight Black** finish

[VX5255TA] 22x18 bass drum, 12x9, 13x10 tom toms, 16x16 floor tom and 14x5.5 snare drum. Includes the following hardware: TH650 tom holder, B320A boom stand, C320A cymbal stand, S320A snare stand, H320A hi-hat, P320A Pedal, T250A Throne



NEW Transparent Cherry Red (CY)



NEW Transparent Midnight Black (MB)



Polished Black (PB)

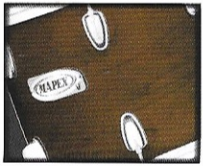

Deep Coffee (WF)



Wax Aquamarine (WQ)

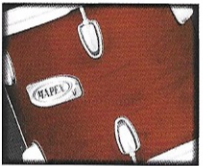

Wax Cherry Red (WY)

FINISHES



VX Series toms are built using Mapex's exclusive Isolated Tom Mount System, which allows the shell to vibrate freely for increased sustain.

VX Series drums are Remo® equipped, including self-muffling bass drum heads.

The VX Series **Fusionease** in the **Transparent Cherry Red** finish

[VX5255TA] 22x18 bass drum, 12x9 and 13x10 tom toms, 16x16 floor tom, 14x5.5 snare drum. Includes the following hardware: TH650 tom holder, B320A boom stand, C320A cymbal stand, S320A snare stand, H320A hi-hat stand, P320A pedal, T250A throne

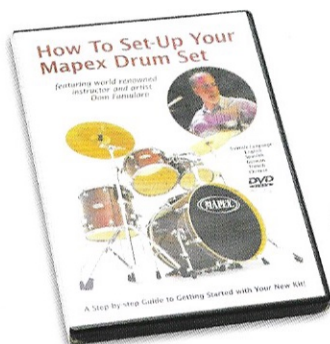

VX Series drum sets come with an instructional DVD hosted by Mapex International Clinician, Dom Famularo



CONFIGURATIONS

Configuration	Bass Drum	Tom Toms	Floor Toms	Snare Drum	Tom Holder	Tom Stand	Boom Stand	Cymbal Stand	Snare Stand	Hi-Hat Stand	Pedal	Throne
<b>5-PIECE DRUM SETS</b>												
Standard VX5255TA	22 x 18	12 x 9 13 x 10	16 x 16	14 x 5.5	TH650		B320A	C320A	S320A	H320A	P320A	T250A
Jazz VX5045TA	20 x 18	10 x 8 12 x 9	14 x 14	14 x 5.5	TH650		B320A	C320A	S320A	H320A	P320A	T250A



COMPONENTS

Bass Drums	
VXB1814A	18 x 14
VXB1816A	18 x 16
VXB2014A	20 x 14
VXB2016A	20 x 16
VXB2018A	20 x 18
VXB2216A	22 x 16
VXB2218A	22 x 18
Tom Toms	
VXT807A	8 x 7
VXT808A	8 x 8
VXT1008A	10 x 8
VXT1009A	10 x 9
VXT1209A	12 x 9
VXT1210A	12 x 10
VXT1310A	13 x 10
VXT1311A	13 x 11
VXT1411A	14 x 11
VXT1412A	14 x 12
Floor Toms	
VXF1210A	12 x 10
VXF1414A	14 x 14
VXF1616A	16 x 16
VXF1816A	18 x 16
Snare Drums	
VXS2506A	12 x 5
VXS3506A	13 x 5
VXS4556A	14 x 5.5
VXS4656A	14 x 6.5

The VX series **Jazz Configuration** in the **Deep Coffee** finish

[VX5045TA]20x18 bass drum, 10x8 and 12x9 tom toms, 14x14 floor tom and 14x5.5 snare drum. Includes the following hardware: TH650 tom holder, B320A boom stand, C320A cymbal stand, S320A snare stand, H320A hi-hat, P320A Pedal, T250A Throne

# QR SERIES



**Jerry Roe**  
Head Automatica,  
The Wreckers

With genuine basswood shells and Mapex's exclusive Isolated Tom Mount System, the QR Series features appointments that rival those found on far more expensive drum sets.

If you're in search of a terrific first drum set or a solid second set for weekend gigs, the QR Series is the kit you need.



The QR Series **Standard Configuration** in the **Angel Wing** wrapped finish.

[QR5254] 22x16 bass drum, 12x9, 13x10 tom toms, 16x16 and 14x5.5 snare drum. Includes the following hardware: TH630 tom holder, B300A boom stand, S300A snare stand, H300A hi-hat stand, P320A pedal.



The QR **Special Edition** in **Gray Sparkle** finish with **Black Powder Fitting**

[QR5255TBQS] bass drum 22x16, 12x9, 13x10 tom toms, 16x16 floor tom, 14 x 5.5 snare drum. Includes the following hardware: TH630 tom holder, B300A boom stand, C300A cymbal stand, S300A snare stand, H300A hi-hat, P320A Pedal, T250A Throne

Shell Construction: 9-ply basswood  
Shell Thickness: 7.2mm

# CONFIGURATIONS

Configuration	Bass Drum	Tom Toms	Floor Toms	Snare Drum	Tom Holder	Boom Stand	Cymbal Stand	Snare Stand	Hi-Hat Stand	Pedal	Throne
<b>5-PIECE DRUM SETS</b>											
Standard QR5255T	22 x 16	12 x 9 13 x 10	16 x 16	14 x 5.5	TH630	B300A	C300A	S300A	H300A	P320A	T250A
Fusionease QR5245T	22 x 16	10 x 8 12 x 9	14 x 14	14 x 5.5	TH630	B300A	C300A	S300A	H300A	P320A	T250A
Voyager QR5244	22 x 16	10 x 8 12 x 9	14 x 14	14 x 5.5	TH630	B300A		S300A	H300A	P320A	
Standard QR5254	22 x 16	12 x 9 13 x 10	16 x 16	14 x 5.5	TH630	B300A		S300A	H300A	P320A	

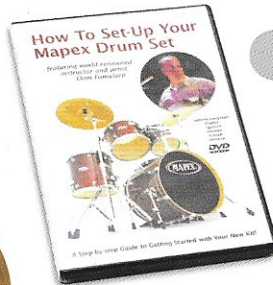

QR Series drum sets come with an instructional DVD hosted by Mapex International Clinician, Dom Famularo



The QR Series **Fusionease Configuration** in the **Blue Sparkle** wrapped finish [QR5245T] 22x16 bass drum, 10x8, 12x9 tom toms, 14x14 floor tom, 14x5.5 snare drum. Includes the following hardware: TH630 tom holder, B300A boom stands, C300A cymbal stands, S300A snare stand, H300A hi-hat stand, P320A pedal, T250A throne.

# COMPONENTS

<b>Bass Drums</b>	
QRB1816	18 x 16
QRB2016	20 x 16
QRB2216	22 x 16
QRB2218	22 x 18
<b>Tom Toms</b>	
QRT807	8 x 7
QRT808	8 x 8
QRT1008	10 x 8
QRT1209	12 x 9
QRT1310	13 x 10
QRT1411	14 x 11
QR16x13	16x13
<b>Floor Toms</b>	
QRF1414	14 x 14
QRF1616	16 x 16
QRF1816	18 x 16
<b>Snare Drums</b>	
QRS4556	14 x 5.5
QRS4656	14 x 6.5

# FINISHES



Peacock Swirl (QW)



Crimson Swirl (CW)



Angel Wing (AS)



Blue Sparkle (NS)



Laser Black (XS)



Black (BL)

# Q SERIES

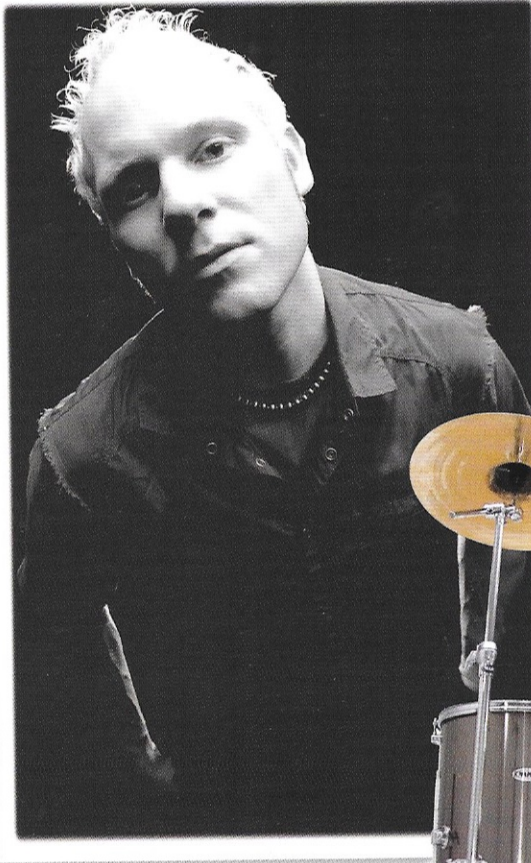

Jason Bowld  
Pitchshifter

## The Q series **Standard Configuration** in **Gray Steel** finish

[Q5255TA] 22x16 bass drum, 12x10 and 13x11tom toms, 16x16 floor tom and 14x5.5 snare drum. Includes the following hardware:TH630 tom holder, B300A boom stand, C300A cymbal stand, S300A snare stand, H300A hi-hat, P320A Pedal, T250A Throne



## Better drums for a better start!

The Q Series is ideal for those just starting out in the world of percussion. Available in three configurations and in two covered finishes, the Q Series is a great drum set at a great price!

- 9-ply 7.2mm basswood shells
- Durable, high-gloss wrapped finish
- Double-braced hardware
- Matching basswood snare drum
- Drummer's throne included
- Includes sturdy TH630 Tom Holder
- Remo® equipped, including self-muffling bass drum head
- Wooden bass drum hoops with matching inlays

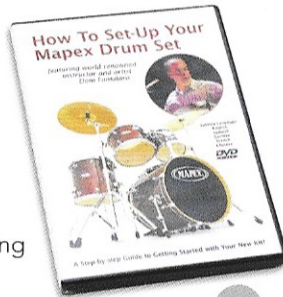

Q Series drum sets come with an instructional DVD hosted by Mapex International Clinician, Dom Famularo.

### FINISHES



Dark Indigo (DI)



Black (BL)

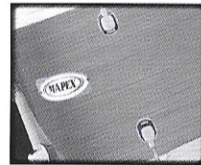

Gray Steel (GT)



Burgundy (BY)



Diamond Silver (DS)

Configuration	Bass Drum	Tom Toms	Floor Toms	Snare Drum	Tom Holder	Cymbal Stand	Snare Stand	Hi-Hat Stand	Pedal	Throne
Standard Q5254TA	22 x 16	12 x 10 13 x 11	16 x 16	14 x 5.5	TH630	C300A	S300A	H300A	P320A	T250A
Jazz Q5044TA	20 x 16	10 x 9 12 x 10	14 x 14	14 x 5.5	TH630	C300A	S300A	H300A	P320A	T250A
Voyager Q5844TA	18 x 16	10 x 9 12 x 10	14 x 14	14 x 5.5	TH630	C300A	S300A	H300A	P320A	T250A

# PRO SERIES SNARE DRUMS

## BRASS

1.2mm Brass Shells, 2.3mm Mapex chrome Powerhoops, Remo® drum heads

BR3355 13 x 3.5

BR4505 14 x 5

BR4655 14 x 6.5

## MAPLE

5.8mm maple shells, 2.3mm Mapex chrome Powerhoops, natural high-gloss finish, Remo® drum heads.

SD3354XN 13 x 3.5

SD4655XN 14 x 6.5

SD2705XN 12 x 7

SD3555XN 13 x 5.5

SD4555XN 14 x 5.5

## STEEL

1mm Stainless Steel Shells, 2.3mm Mapex Chrome Powerhoops, Remo® drum heads

ST0554 10 x 5.5

ST3354 13 x 3.5

ST3554 13 x 5.5

ST4505 14 x 5

ST4654 14 x 6.5



# SCHOOL ITEM

## Bell Kit

Model : MK32P

MK32PC (w/easy roll cart)

- 32-note 2 1/2 Octave Bell Set
- Adjustable Stand
- Sheet Music Holder
- Includes Mallets
- Durable Carry Bag



## Snare Drum Kit

Model : MK14D, MK14DC (w/easy roll cart)

- 14 x 5.5 10-lug Snare Drum
- Adjustable Snare Stand
- Includes Practice Pad and Snare Muffler
- Includes Drum Sticks
- Durable Carry Bag



## Combination Bell/Snare Kit

Model : MK1432DP (w/easy roll cart)

- 32-note 2 1/2 Octave Bell Set
- Sheet Music Holder
- 14 x 3.5 10-lug Snare Drum
- Adjustable Bell stand
- Adjustable Snare Stand
- Includes Practice Pad
- Includes Mallets and Sticks
- Durable Carry Bag



# PRO SERIES SNARE DRUMS

## BRASS

1.2mm Brass Shells, 2.3mm Mapex chrome Powerhoops, Remo® drum heads

- BR3355 13 x 3.5
- BR4505 14 x 5
- BR4655 14 x 6.5



## MAPLE

5.8mm maple shells, 2.3mm Mapex chrome Powerhoops, natural high-gloss finish, Remo® drum heads.

- SD3354XN 13 x 3.5
- SD4655XN 14 x 6.5
- SD2705XN 12 x 7
- SD3555XN 13 x 5.5
- SD4555XN 14 x 5.5



## STEEL

1mm Stainless Steel Shells, 2.3mm Mapex chrome Powerhoops, Remo® drum heads

- ST0554 10 x 5.5
- ST3354 13 x 3.5
- ST3554 13 x 5.5
- ST4505 14 x 5
- ST4654 14 x 6.5



## SCHOOL ITEM

### Snare Drum Kit

Model :  
MK14D,  
MK14DC (w/easy roll cart)

- 14 x 5.5 10-lug Snare Drum
- Adjustable Snare Stand
- Includes Practice Pad and Snare Muffler
- Includes Drum Sticks
- Durable Carry Bag



### Combination Bell/Snare Kit

Model : MK1432DP (w/easy roll cart)

- 32-note 21/2 Octave Bell Set
- Sheet Music Holder
- 14 x 3.5 10-lug Snare Drum
- Adjustable Bell stand
- Adjustable Snare Stand
- Includes Practice Pad
- Includes Mallets and Sticks
- Durable Carry Bag

### Bell Kit

Model :  
MK32P,  
MK32PC (w/easy roll cart)

- 32-note 21/2 Octave Bell Set
- Adjustable Stand
- Sheet Music Holder
- Includes Mallets
- Durable Carry Bag



# BLACK PANTHER SNARE DRUM



## THICK FLAMED MAPLE 14x6

**Shell Thickness:** 12mm  
**Shell Finish:** Honey Maple Burst  
**Hoops:** Die Cast Hoops  
**Hoop Finish:** Chrome  
**Snare:** 20-strand

BPFM4600THT

The 15-ply extra thick shell features a traditional deep snare bed along with a rounded bearing edge that provides increased shell to head contact. The result is a warm, dark, full-bodied sound with incredibly soft feel. The flamed maple exterior veneer is finished in high-gloss, hand applied lacquer which brings out the rich grain of the wood.



## MAPLE

Mapex 2.3mm Powerhoops are used on selected models and provide maple strength and response for the hardest rimshots. Black Panther Snare Drums come equipped with genuine REMO® heads.

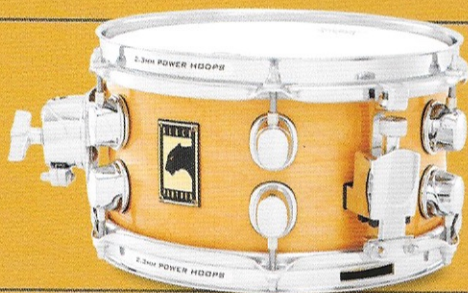

## Traditional MAPLE 10x5.5

**Shell Thickness:** 5.1mm  
**Shell Finish:** Wax Natural  
**Hoops:** 2.3mm Powerhoops  
**Hoop Finish:** Chrome  
**Snare:** 16-strand

I.T.S. off-the-shell mounting system

BPML0550CWN



## Traditional MAPLE 13x6

**Shell Thickness:** 5.1mm  
**Shell Finish:** Wax Natural  
**Hoops:** 2.3mm Powerhoops  
**Hoop Finish:** Chrome  
**Snare:** 20-strand

BPML3600CWN



## Traditional MAPLE 14x6.5

**Shell Thickness:** 5.1mm  
**Shell Finish:** Wax Natural  
**Hoops:** 2.3mm Powerhoops  
**Hoop Finish:** Chrome  
**Snare:** 20-strand

BPML4650CWN

BPBE4550FB

**BIRDSEYE MAPLE** 14x5.5

**Shell Thickness:** 6.1mm  
**Shell Finish:** Satin Black  
**Hoops:** Die Cast Hoops  
**Hoop Finish:** Black Chrome  
**Snare:** 20-strand



BPML3600BTB

**BLACK LACQUERED MAPLE** 13x6

**Shell Thickness:** 5.1mm  
**Shell Finish:** Transparent Gloss Black  
**Hoops:** Die Cast Hoops  
**Hoop Finish:** Black Chrome  
**Snare:** 20-strand



BPML4550BTB

**BLACK LACQUERED MAPLE** 14x5.5

**Shell Thickness:** 5.1mm  
**Shell Finish:** Transparent Gloss Black  
**Hoops:** Die Cast Hoops  
**Hoop Finish:** Black Chrome  
**Snare:** 20-strand



BPML4650BTB

**BLACK LACQUERED MAPLE** 14x6.5

**Shell Thickness:** 5.1mm  
**Shell Finish:** Transparent Gloss Black  
**Hoops:** Die Cast Hoops  
**Hoop Finish:** Black Chrome  
**Snare:** 20-strand



BPBE4650FB

**BIRDSEYE MAPLE** 14x6.5

**Shell Thickness:** 6.1mm  
**Shell Finish:** Satin Black  
**Hoops:** Die Cast Hoops  
**Hoop Finish:** Black Chrome  
**Snare:** 20-strand







### PREMIUM WALNUT 13x6

**Shell Thickness:** 8.5mm  
**Shell Finish:** Brown Sugar Burst  
**Hoops:** Die Cast Hoops  
**Hoop Finish:** Black Chrome  
**Snare:** 42-strand

BPWT3600TBW



## WALNUT

With a high-gloss "Brown Sugar Burst" finish, the Black Panther Walnut Series combines beautiful looks with rich and saturating sonic texture.

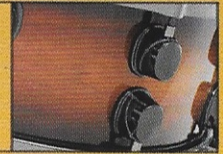

### PREMIUM WALNUT 14x5.5

**Shell Thickness:** 8.5mm  
**Shell Finish:** Brown Sugar Burst  
**Hoops:** Die Cast Hoops  
**Hoop Finish:** Black Chrome  
**Snare:** 20-strand

BPWT4550TBW



### PREMIUM WALNUT 14x6.5

**Shell Thickness:** 8.5mm  
**Shell Finish:** Brown Sugar Burst  
**Hoops:** Die Cast Hoops  
**Hoop Finish:** Black Chrome  
**Snare:** 42-strand

BPWT4650TBW



## CHERRY

With tone that's slightly sweeter and more full-bodied than maple, the Black Panther Cherry Series is distinctive in both its sound and its looks. The high-gloss natural finished drums are appointed with 24K gold plated lugs and hoops for an extra touch of luxury.



### CHERRY 13x6

**Shell Thickness:** 5.1mm  
**Shell Finish:** Wax Natural  
**Hoops:** Die Cast Hoops  
**Hoop Finish:** 24K Gold Plated  
**Snare:** 20-strand

BPCW3600WN

BPCW4550WN

**CHERRY** 14x5.5

**Shell Thickness:** 5.1mm  
**Shell Finish:** Wax Natural  
**Hoops:** Die Cast Hoops  
**Hoop Finish:** 24K Gold Plated  
**Snare:** 20-strand



BPCW4650WN

**CHERRY** 14x6.5

**Shell Thickness:** 5.1mm  
**Shell Finish:** Wax Natural  
**Hoops:** Die Cast Hoops  
**Hoop Finish:** 24K Gold Plated  
**Snare:** 42-strand



Black Panther Brass Snare are built using 1.2mm pure brass for a tone that's slightly more delicate than steel. High end tones are faithfully produced with precise sensitivity and plenty of power when you need it most.

**BRASS**

BPBR3551A

**PREMIUM BRASS** 13x5.5

**Shell Thickness:** 1.2mm  
**Shell Finish:** Natural Polished Brass  
**Hoops:** 2.3mm Powerhoops  
**Hoop Finish:** Black Chrome  
**Snare:** 20-strand



BPBR4551A

**PREMIUM BRASS** 14x5.5

**Shell Thickness:** 1.2mm  
**Shell Finish:** Natural Polished Brass  
**Hoops:** 2.3mm Powerhoops  
**Hoop Finish:** Black Chrome  
**Snare:** 20-strand



BPBR455HB

**HAMMERED BRASS** 14x5.5

**Shell Thickness:** 1.2mm  
**Shell Finish:** Black Plated Brass  
**Hoops:** Die Cast Hoops  
**Hoop Finish:** Black Chrome  
**Snare:** 20-strand





**HAMMERED BRASS** 14x6.5

**Shell Thickness:** 1.2mm  
**Shell Finish:** Black Plated Brass  
**Hoops:** Die Cast Hoops  
**Hoop Finish:** Black Chrome  
**Snare:** 20-strand

BPBR465HB



**STEEL**

Black Panther Steel Snare Drums are famous for a razor sharp cut and explosive overtones. Mapex 2.3mm Powerhoops provide superior sensitivity and remarkable articulation.



**STAINLESS STEEL** 10x5.5

**Shell Thickness:** 1.0mm  
**Shell Finish:** Black Plated  
**Hoops:** 2.3mm Powerhoops  
**Hoop Finish:** Black Chrome  
**Snare:** 16-strand

I.T.S. off-the-shell mounting system

BPST055I



**STAINLESS STEEL** 14x5.5

**Shell Thickness:** 1.0mm  
**Shell Finish:** Black Plated  
**Hoops:** 2.3mm Powerhoops  
**Hoop Finish:** Black Chrome  
**Snare:** 20-strand

BPST4551A



**STAINLESS STEEL** 14x6.5

**Shell Thickness:** 1.0mm  
**Shell Finish:** Black Plated  
**Hoops:** 2.3mm Powerhoops  
**Hoop Finish:** Black Chrome  
**Snare:** 20-strand

BPST4651A



**HAMMERED STAINLESS STEEL**  
14x5.5

**Shell Thickness:** 1.0mm  
**Shell Finish:** Chrome Plated  
**Hoops:** Die Cast Hoops  
**Hoop Finish:** Chrome  
**Snare:** 20-strand

BPST455H

BPPB4551

**PHOSPHOR BRONZE** 14x5.5

**Shell Thickness:** 1.0mm  
**Shell Finish:** Natural Polished Bronze  
**Hoops:** 2.3mm Powerhoops  
**Hoop Finish:** Black Chrome  
**Snare:** 20-strand

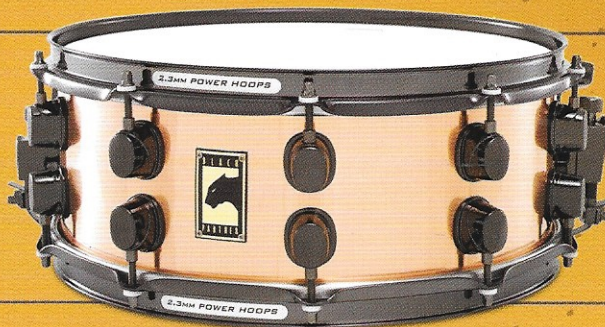

BPPB4651

**PHOSPHOR BRONZE** 14x6.5

**Shell Thickness:** 1.0mm  
**Shell Finish:** Natural Polished Bronze  
**Hoops:** 2.3mm Powerhoops  
**Hoop Finish:** Black Chrome  
**Snare:** 42-strand



Black Panther Phosphor Bronze Snares produce a unique sound that possesses the clarity and brightness that you would expect from a metal shell, but with a warmth and depth of a wood snare drum. The hand hammered versions create an even more distinctive sound.

**BRONZE**

BPPB455H

**HAMMERED PHOSPHOR BRONZE**

14x5.5

**Shell Thickness:** 1.0mm  
**Shell Finish:** Natural Polished Bronze  
**Hoops:** 2.3mm Powerhoops  
**Hoop Finish:** Black Chrome  
**Snare:** 20-strand



BPPB465H

**HAMMERED PHOSPHOR BRONZE**

14x6.5

**Shell Thickness:** 1.0mm  
**Shell Finish:** Natural Polished Bronze  
**Hoops:** 2.3mm Powerhoops  
**Hoop Finish:** Black Chrome  
**Snare:** 20-strand





**MAPEX HARDWARE**

# MAPEX SINGLE PEDALS

## P950A

- Double Chain Drive
- Adjustable Stabilizer Bearing
- Fully Adjustable Spring Tension
- Tri-Tonal Beater
- Solid Steel Skid-proof Stabilizer Plate
- Retractable Floor Spikes
- Patented Extra Large Floating Hoop Clamp
- Drum Key Holder



## P750A

- Double Chain Drive
- Fully Adjustable Spring Tension
- Tri-Tonal Beater
- Solid Steel Skid-proof Stabilizer Plate
- Retractable Floor Spikes
- Patented Floating Hoop Clamp
- Drum Key Holder



## P550A

- Single Chain Drive
- Fully Adjustable Spring Tension
- Tri-Tonal Beater
- Steel Stabilizer Bars with Skid-Proof Plate
- Retractable Floor Spikes



## P320A

- Single Chain Drive
- Fully Adjustable Spring Tension
- Hard Felt Beater
- Stabilizing Compact Radius Rods
- Retractable Floor Spikes



# MAPEX DOUBLE PEDALS

## P980A

- Double Chain Drive
- Adjustable Stabilizer Bearing
- Fully Adjustable Spring Tension
- Tri-Tonal Beaters
- Fully Independent Universal Linkage Adjustment
- Rubber Sealed U-Joints
- Solid Steel Skid-proof Stabilizer Plates
- Retractable Floor Spikes
- Patented Extra Large Floating Hoop Clamp
- Drum Key Holder



## P580A

- Single Chain Drive
- Fully Adjustable Spring Tension
- Tri-Tonal Beaters
- Fully Independent Universal Linkage Adjustment
- Rubber Sealed U-Joints
- Steel Stabilizer Bars with Skid-Proof Plates
- Retractable Floor Spikes
- Patented Floating Hoop Clamp
- Drum Key Holder



## P380A

**NEW** Also available Left-Footed Double Pedal P380LA

- Single Chain Drive
- Fully Adjustable Spring Tension
- Duo-tone Felt/ABS Beaters
- Fully Independent Universal Linkage Adjustment
- Steel Stabilizer Bars and Radius Rods
- Retractable Floor Spikes



## P390A

- Same as P380A, comes with padded Nylon Carry Bag

## H950A

- Tru-Direct-Pull™ Drive System
- Adjustable Angle Footboard
- 10-Stop Wide-range Tension Adjustment with Gauge
- OS Cymbal Accentuator for Top Cymbal
- Fully Adjustable Tri-Nodal Cymbal Seat
- Retractable Floor Spikes
- Dual Tube Construction with Slip-Proof Nylon Inner Sleeve
- Die Cast Memory Lock
- 360° Rotating Leg Assembly
- Double Braced Legs

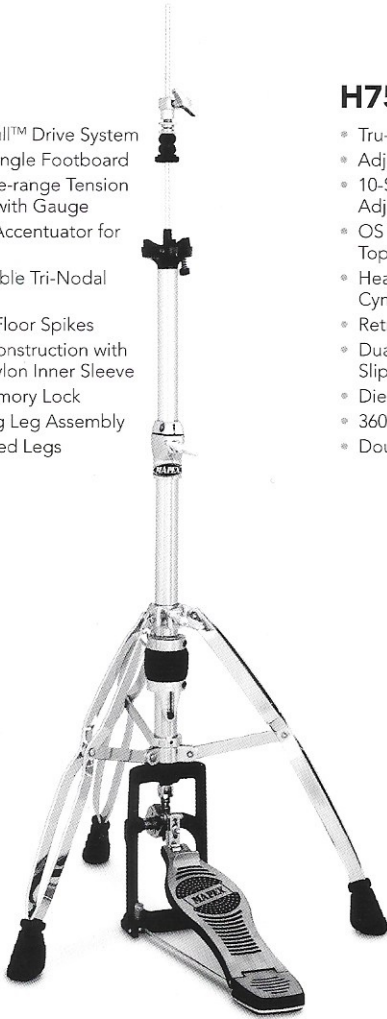

## H750A

- Tru-Direct-Pull™ Drive System
- Adjustable Angle Footboard
- 10-Stop Wide-range Tension Adjustment
- OS Cymbal Accentuator for Top Cymbal
- Heavy Duty Felt Bottom Cymbal Seat
- Retractable Floor Spikes
- Dual Tube Construction with Slip-Proof Nylon Inner Sleeve
- Die Cast Memory Lock
- 360° Rotating Leg Assembly
- Double Braced Legs

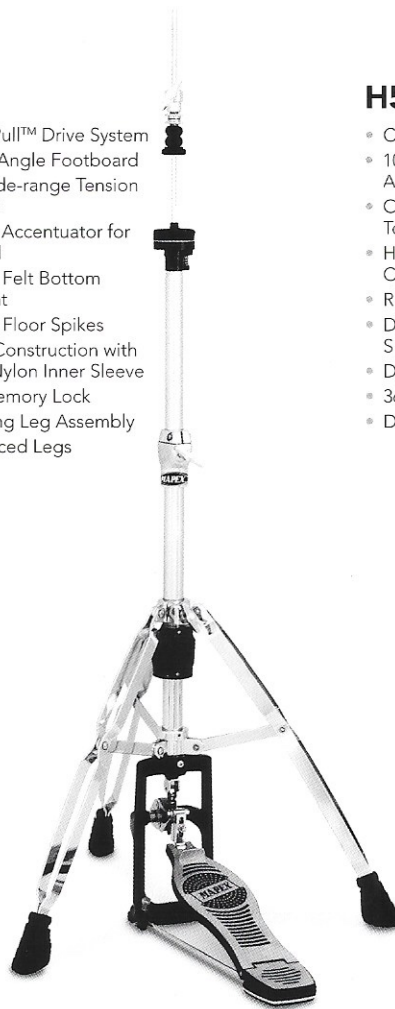

## H550A

- Chain Pull Drive System
- 10-Stop Wide-range Tension Adjustment
- OS Cymbal Accentuator for Top Cymbal
- Heavy Duty Felt Bottom Cymbal Seat
- Retractable Floor Spike
- Dual Tube Construction with Slip-Proof Nylon Inner Sleeve
- Die Cast Memory Lock
- 360° Rotating Leg Assembly
- Double Braced Legs



## H350A

- Chain Pull Drive System
- OS Cymbal Accentuator for Top Cymbal
- Heavy Duty Felt Bottom Cymbal Seat
- Retractable Floor Spike
- Dual Tube Construction with Slip-Proof Nylon Inner Sleeve
- Die Cast Memory Lock



## H320A

- Chain Pull Drive System
- Heavy Duty Felts for Top Cymbal
- Heavy Duty Felt Bottom Cymbal Seat
- Retractable Floor Spike
- Dual Tube Construction with Slip-Proof Nylon Inner Sleeve
- Die Cast Memory Lock
- Double Braced Legs





# MAPEX SNARE STANDS

## S950A

- Ground Reaching Center Shaft for extra low positioning for deep snares
- Universal Ball-in-Socket Snare Basket Tilter
- Dual Tube Construction with Slip-Proof Nylon Inner Sleeve
- Die Cast Memory Lock



## S750A

- Universal Ball-in-Socket Snare Basket Tilter
- Dual Tube Construction with Slip-Proof Nylon Inner Sleeve
- Die Cast Memory Lock



## S550A

- Multi-tooth Ratchet Snare Basket Tilter
- Dual Tube Construction with Slip-Proof Nylon Inner Sleeve
- Die Cast Memory Lock



## C950A

- Universal Ball-in-Socket Cymbal Tilter
- Triple Tube Construction with Slip-Proof Nylon Inner Sleeve
- OS Cymbal Accentuators
- Die Cast Memory Locks
- Double Braced Legs



## S350A

- Multi-tooth Ratchet Snare Basket Tilter
- Dual Tube Construction with Slip-Proof Nylon Inner Sleeve
- Die Cast Memory Lock



## S320A

- Multi-tooth Ratchet Snare Basket Tilter
- Dual Tube Construction with Slip-Proof Nylon Inner Sleeve
- Die Cast Memory Lock
- Double Braced Legs



## C750A

- Universal Ball-in-Socket Cymbal Tilter
- Triple Tube Construction with Slip-Proof Nylon Inner Sleeve
- OS Cymbal Accentuators
- Die Cast Memory Locks
- Double Braced Legs

## C350A

- Multi-Tooth Ratchet Cymbal Tilter
- Dual Tube Construction with Slip-Proof Nylon Inner Sleeve
- OS Cymbal Accentuators
- Die Cast Memory Lock

## B995A

- Three Cymbal Placements
- Universal Ball-in-Socket Cymbal Tilters
- Dual Tube Construction with Slip-Proof Nylon Inner Sleeve
- OS Cymbal Accentuators
- Die Cast Memory Locks
- Double Braced Legs

## C550A

- Multi-Tooth Ratchet Cymbal Tilter
- Triple Tube Construction with Slip-Proof Nylon Inner Sleeve
- OS Cymbal Accentuators
- Die Cast Memory Locks
- Double Braced Legs

## C320A

- Multi-Tooth Ratchet Cymbal Tilter
- Dual Tube Construction with Slip-Proof Nylon Inner Sleeve
- Heavy Duty Cymbal Felts
- Die Cast Memory Lock
- Double Braced Legs

## B990A

- Two Cymbal Placements
- Universal Ball-in-Socket Cymbal Tilters
- Dual Tube Construction with Slip-Proof Nylon Inner Sleeve
- OS Cymbal Accentuators
- Die Cast Memory Locks
- Double Braced Legs

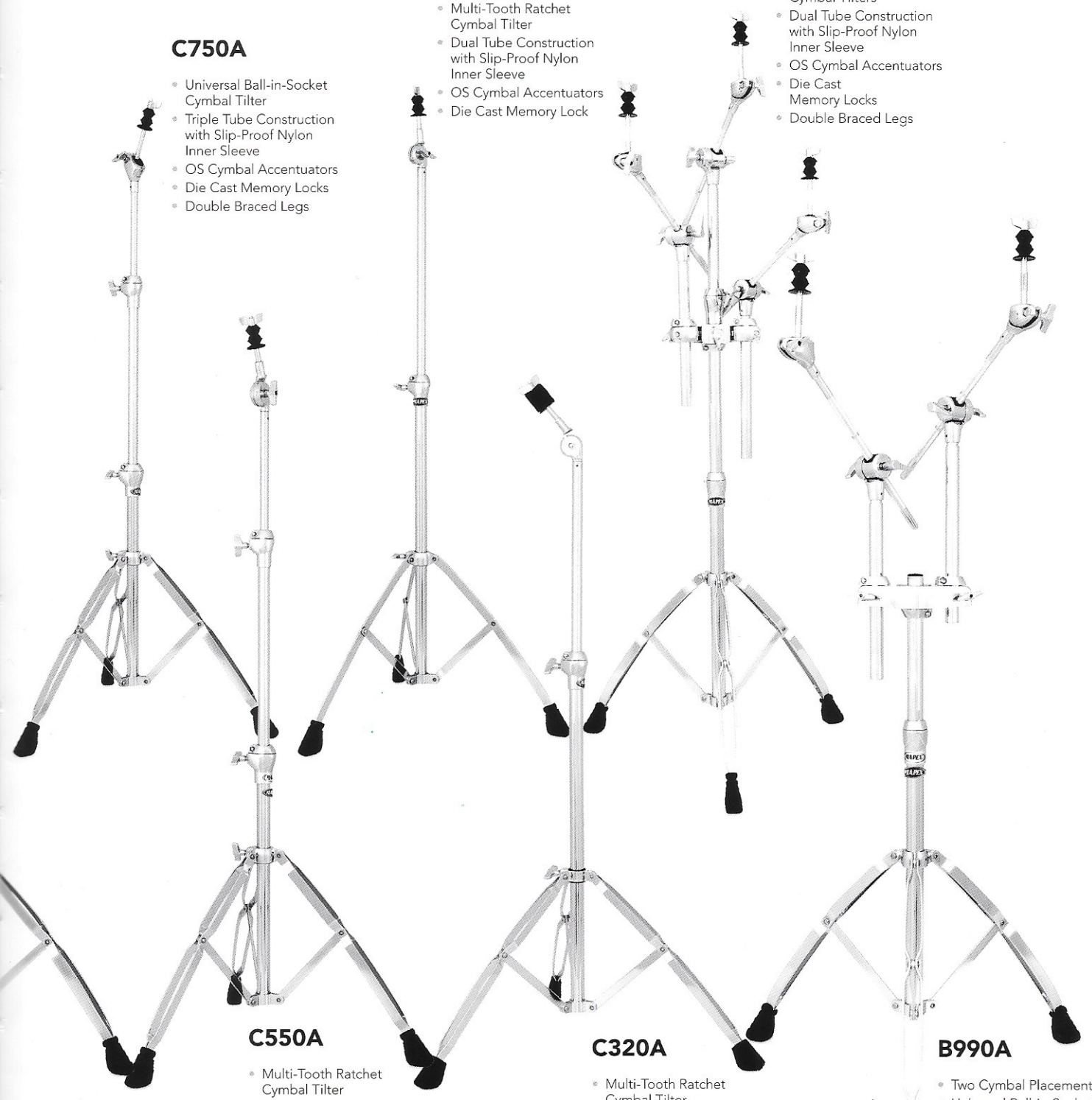

# MAPEX BOOM STANDS

## B750A

- Universal Ball-in-Socket Cymbal Tilter
- Knurled Hideaway Boom Arm
- Triple Tube Construction with Slip-Proof Nylon Inner Sleeve
- OS Cymbal Accentuators
- Die Cast Memory Locks
- Double Braced Legs



## B560A

- 2.2LB Counterweight
- Multi-Tooth Ratchet Cymbal Tilter
- Triple Tube Construction with Slip-Proof Nylon Inner Sleeve
- OS Cymbal Accentuators
- Die Cast Memory Locks
- Double Braced Legs



## B320A

- Multi-Tooth Ratchet Cymbal Tilter
- Dual Tube Construction with Slip-Proof Nylon Inner Sleeve
- Heavy Duty Cymbal Felts
- Die Cast Memory Lock
- Double Braced Legs



## B950A

- Universal Ball-in-Socket Cymbal Tilter
- Knurled Hideaway Boom Arm
- Triple Tube Construction with Slip-Proof Nylon Inner Sleeve
- OS Cymbal Accentuators
- Die Cast Memory Locks
- Double Braced Legs

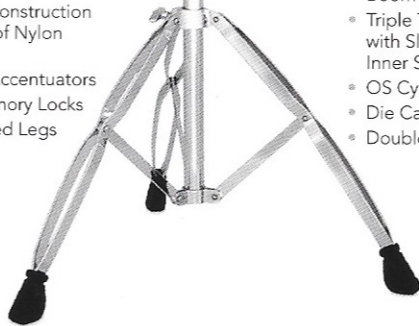

## B550A

- Multi-Tooth Ratchet Cymbal Tilter
- Knurled Hideaway Boom Arm
- Triple Tube Construction with Slip-Proof Nylon Inner Sleeve
- OS Cymbal Accentuators
- Die Cast Memory Locks
- Double Braced Legs



## B350A

- Multi-Tooth Ratchet Cymbal Tilter
- Dual Tube Construction with Slip-Proof Nylon Inner Sleeve
- OS Cymbal Accentuators
- Die Cast Memory Lock



# MAPEX MULTI-USE STANDS

## TS965A

- Two Cymbal Placements
- One Tom Holder
- Universal Ball-in-Socket Cymbal Tilter
- Universal Ball-in-Socket Tom Arm
- Dual Tube Construction with Slip-Proof Nylon Inner Sleeve
- Knurled Hideaway Boom Arm
- OS Cymbal Accentuators
- Die Cast Memory Locks
- Double Braced Legs

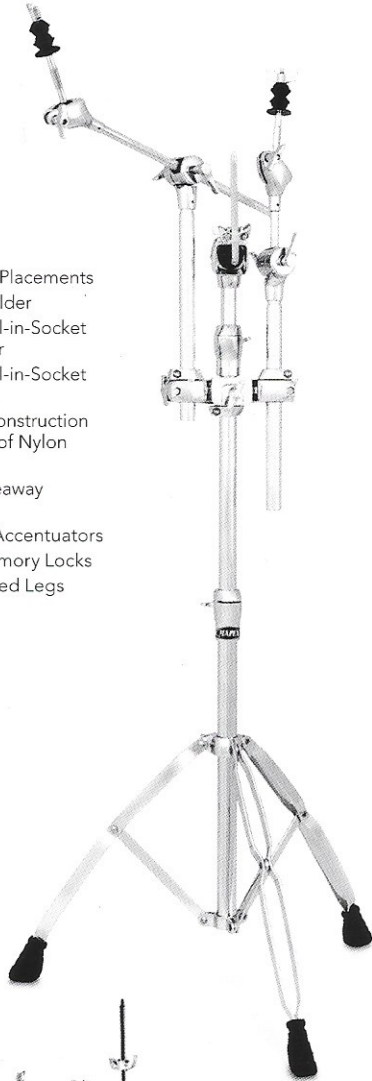

## TS960A

- One Cymbal Placement
- One Tom Holder
- Universal Ball-in-Socket Cymbal Tilter
- Universal Ball-in-Socket Tom Arm
- Dual Tube Construction with Slip-Proof Nylon Inner Sleeve
- Knurled Hideaway Boom Arm
- OS Cymbal Accentuators
- Die Cast Memory Locks
- Double Braced Legs



## TS950A

- Two Independently Adjustable Tom Holders
- Dual Tube Construction with Slip-Proof Nylon Inner Sleeve
- Universal Ball-in-Socket Tom Arm
- Die Cast Memory Locks
- Double Braced Legs



## TS550A

- Two Tom Holders
- Dual Tube Construction with Slip-Proof Nylon Inner Sleeve
- Universal Ball-in-Socket Tom Arm
- Die Cast Memory Locks
- Double Braced Legs



# MAPEX DRUMMER'S THRONES

## NEW T765A

- Newly Designed Saddle-style Cushioned Seat
- Contoured Reinforced Foam Seat 17" wide by 4" thick
- Cloth Top Seat Cover
- Die Cast Memory Lock
- Threaded Steel Rod Height Adjustment with Threaded Tube Collar Lock
- 18" - 26" Height Range
- Double Braced "Natural Curve" Legs for Extra Stability



## NEW T760A

- Newly Designed Round Cushioned Seat
- 14" Diameter by 4" Thick
- Cloth Top Seat Cover
- Die Cast Memory Lock
- Threaded Steel Rod Height Adjustment with Threaded Tube Collar Lock
- 18" - 26" Height Range
- Double Braced "Natural Curve" Legs for Extra Stability



## T755A

- Newly Designed Saddle-style Cushioned Seat
- Contoured Reinforced Foam Seat 17" wide by 4" thick
- Durable Soft-vinyl Seat Cover
- Die Cast Memory Lock
- Threaded Steel Rod Height Adjustment with Threaded Tube Collar Lock
- 18" - 26" Height Range
- Double Braced "Natural Curve" Legs for Extra Stability

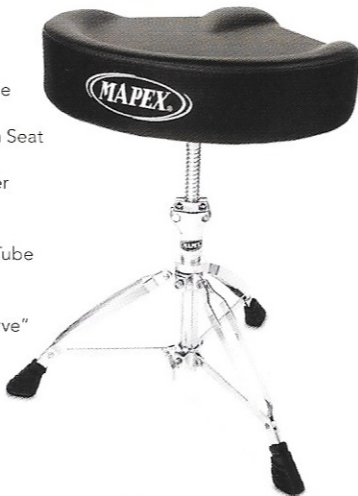

## T750A

- Newly Designed Round Cushioned Seat
- 14" Diameter by 4" Thick
- Durable Soft-vinyl Seat Cover
- Die Cast Memory Lock
- Threaded Steel Rod Height Adjustment with Threaded Tube Collar Lock
- 18" - 26" Height Range
- Double Braced "Natural Curve" Legs for Extra Stability



## T575A

- Newly Designed Saddle-style Cushioned Seat
- Contoured Reinforced Foam Seat 17" wide by 4" thick
- Durable Soft-vinyl Seat Cover
- Die Cast Memory Lock
- Steel Tube Height Adjustment with Tube Collar Lock
- 16.1" - 24.4" Height Range
- Double Braced Legs

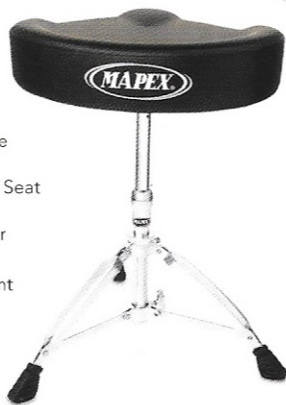

## T570A

- Newly Designed Round Cushioned Seat
- 14" Diameter by 4" Thick
- Durable Soft-vinyl Seat Cover
- Die Cast Memory Lock
- Steel Tube Height Adjustment with Tube Collar Lock
- 16.1" - 24.4" Height Range
- Double Braced Legs



## T550A

- Round Cushioned Seat
- 13" Diameter by 2.5" thick
- Durable Soft-vinyl Seat Cover
- Die Cast Memory Lock
- Steel Tube Height Adjustment with Tube Collar Lock
- 16.1"-24.4" Height Range
- Double Braced Legs



## T270A

- Round Cushioned Seat
- 12" Diameter by 2.5" thick
- Durable Soft-vinyl Seat Cover
- 6-position Keyway Rod with Stop Lock Nut
- 17.3"-22" Height Range
- Double Braced Legs



# MAPEX MULTI-CLAMPS

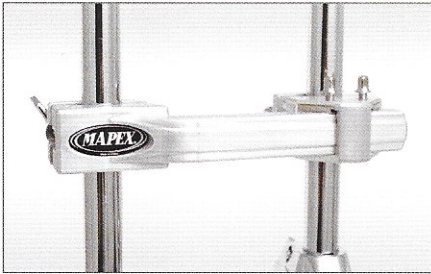

## NEW AC910

Horizontal adjustable multi-purpose clamp to replace AC901

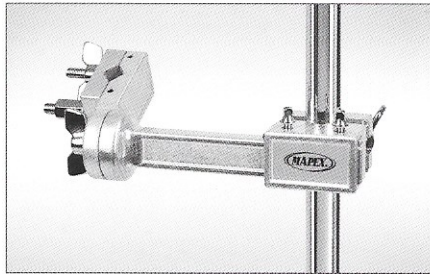

## AC905

Combination side-ratchet adjustable multi-purpose clamp

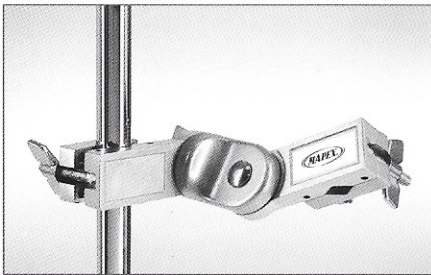

## AC902

Dual-angle adjustable multi-purpose clamp

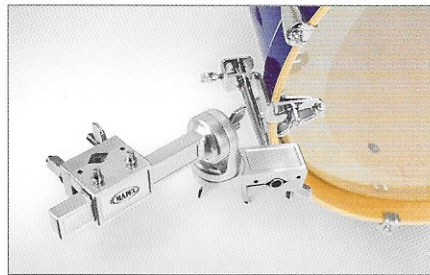

## AC906

Bass drum/hi-hat attachment clamp for close placement in double bass set-ups



## NEW AC911

Add-on boom arm with combination multi-clamp. Includes 12-inch knurled boom arm with universal ball-in-socket tilter and OS Cymbal Accentuator

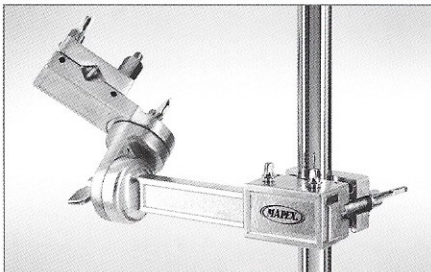

## AC903

Combination center-ratchet adjustable multi-purpose clamp

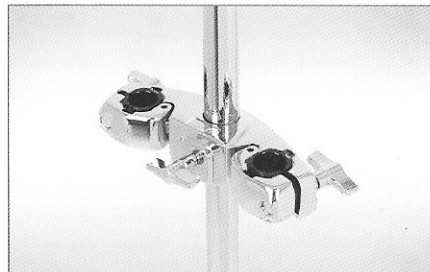

## AC908

Cymbal/Tom arm multi-purpose platform with center hole to fit all 25.4mm stands



## NEW AC912

Cowbell/Accessory holder for bass drum

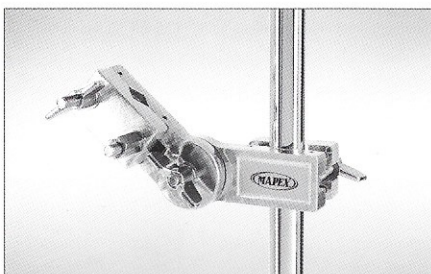

## AC904

Center-ratchet adjustable multi-purpose clamp



## AC909

Adjustable bass drum lift for 18-inch bass drums

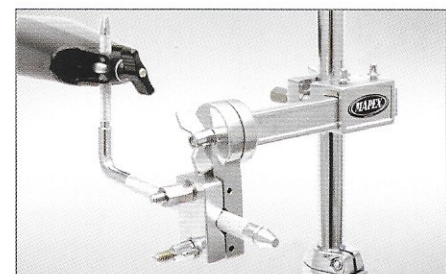

## NEW AC913

Cowbell/Accessory holder for cymbal stand

# MAPEX TOM / CYMBAL ARMS

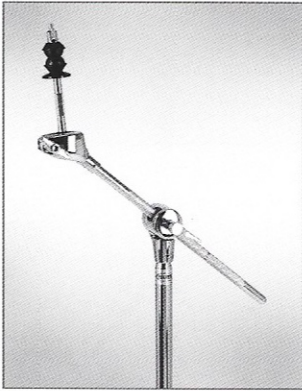

**B75**  
2-piece hideaway boom cymbal arm (12-inch) with universal ball-in-socket tilter, knurled boom arm and OS Cymbal Accentuator

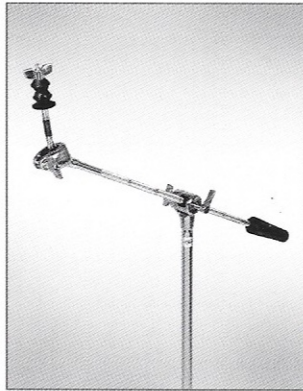

**B78**  
2-piece hideaway boom cymbal arm (20.1-inch) with 2.2 lb counterweight, universal ball-in-socket tilter, knurled boom arm and OS Cymbal Accentuator



**NEW CH72**  
Adjustable Tension remote hi-hat arm with heavy duty felt bottom cymbal seat and OS Cymbal Accentuator



**TH685**  
Tom shaft and arm set for Orion Series  
Tube Diameter: 25mm

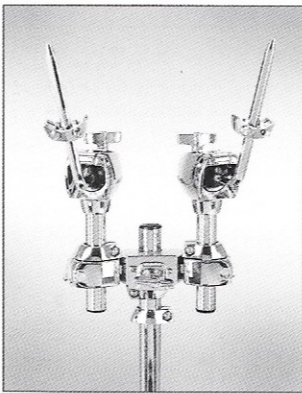

**TH682**  
Tom shaft and arm set for Saturn Series  
Tube Diameter: 25mm

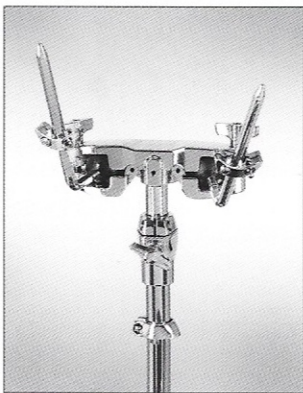

**TH675**  
Tom shaft and arm set for Pro M Series  
Tube Diameter: 25mm

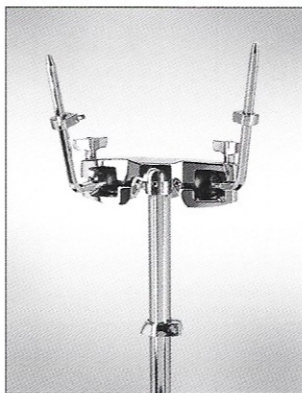

**TH650**  
Tom shaft and arm set for M, QR, VX and Q Series. Tube Diameter: 25mm



**TH683**  
Single Tom Holder for Orion, Saturn and Pro M Series bass drums  
Tube Diameter: 25.4mm



**TH653**  
Single Tom Holder for M Birch, VX, QR and Q Series bass drums  
Tube Diameter: 25.4mm



**TH684**  
Single Tom arm for add-on toms attached to tom stands  
Tube Diameter: 22.2mm

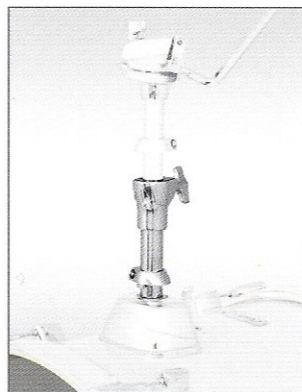

**6705-075A**  
Tube expander allows TH684 Single Tom Arm (22mm) to fit into standard size bass drum tom holder receiver (25mm).



## HI-HAT CLUTCH

Hi-Hat Model	Part Number
H950A/H750A/H550A/H350A	2680-346A
H320A/H300A	2670-346A

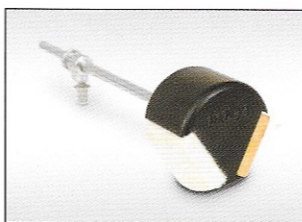

## TRI-TONAL BASS DRUM BEATER

Rotating beater with maple, felt and ABS beater. PN: 4680-515A



## REPLACEMENT LUGS

4 per pack. Fits Saturn and Orion Bass Drums when removing tom mount apparatus. Available in Chrome or Black Chrome.

Part No.	Plating
0702-D02A4	Chrome
0712-D13A4	Black
0702-D07A4	Gold



## BLACK PANTHER DELUXE SNARE BAG

Sturdy, easy-care rubberized exterior, soft padded interior protects snare drums, heavy duty zipper, padded handle and shoulder strap. Holds up to 14x6.5 snare drum.

PN: EBG146500BP

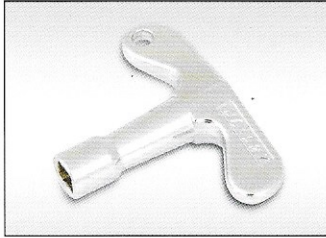

## MAPEX DRUM KEY

Works with tension and adjustment screws from most manufacturers.  
PN: KZWA058

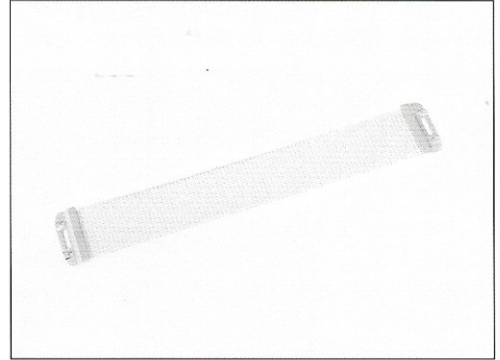

## SNARE WIRES

Available in Chrome, Black or Gold Plated.

Part No.	Length	Strands	Plating
1S582850A	10-inch	16	Chrome
11A394850A	12-inch	20	Chrome
1K394850A	13-inch	20	Chrome
18794850A	14-inch	20	Chrome
1F6W0850	13-inch	42	Chrome
187W0850	14-inch	42	Chrome

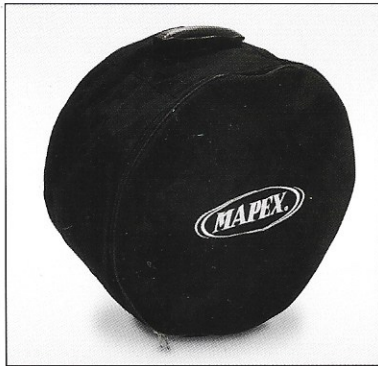

## PADDED DRUM BAG SETS

Soft gig bags embroidered with the Mapex logo. Features padded compartments and handles, reinforced zippers.

Model	Configuration	Sizes
DB-T24204	Fusion (5225)	22 Bass, 10 Tom, 12 Tom, 14 Tom, 14x5.5 Snare
DB-T26324	Standard (5255)	22 Bass, 12 Tom, 13 Tom, 16 Floor Tom, 14x5.5 Snare
DB-T2624	Classic (4266)	22x20 Bass, 12 Tom, 16 Floor Tom, 14x7 Snare
DB-T286324	Classic Plus (6296)	22x20 Bass, 12 Tom, 13 Tom, 16 Floor Tom, 18 Floor Tom, 14x7 Snare

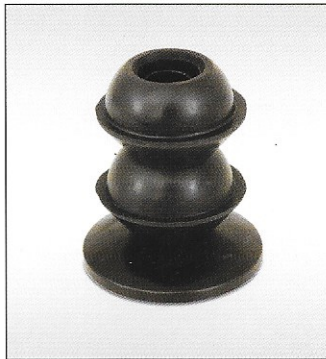

## OS CYMBAL ACCENTUATORS

Enhances cymbal sustain. (3 pc.)  
PN: 3480-355X



## MAPEX LOGO STICKERS

Features Mapex "Swirl" logo in 10-inch and 3-inch sizes. Ideal for bass drum heads and road cases.  
PN: PMK-M269 (white) / PMK-M270 (black)

## LOGO BASS DRUM HEADS

REMO® Weatherking  
Ambassador Ebony  
Powerstroke Front Head

REMO® UT Self-Muffling  
Ebony Front Head

Model	Size	Model	Size
0318-618BB-MP	18-inch	0334-618CB-MP	18-inch
0318-620BB-MP	20-inch	0334-620CB-MP	20-inch
0318-622BB-MP	22-inch	0334-622CB-MP	22-inch
0318-624BB-MP	24-inch	0334-624CB-MP	24-inch

**NEW**  
REMO® Weatherking  
White Powerstroke 3  
Front Head

Model	Size
0318-K18BB-MP	18-inch
0318-K20BB-MP	20-inch
0318-K22BB-MP	22-inch
0318-K24BB-MP	24-inch



## NEW MAPEX ROLLING HARDWARE BAG

Durable fabric Mapex rolling hardware bag with side compartments. Holds up to six pieces of hardware including stands and pedals. Bag Dimensions: 38-in. long x 14-in. wide x 10-in. deep PN: PMK-M113





**Chris Adler**  
*Lamb of God*  
/ USA /



**Sam Aliano**  
*Summer Rose*  
/ USA /



**Elias Andra**  
*Julien-k*  
/ USA /



**Brian Barnett**  
*Hank Williams Jr.*  
/ USA /



**Frank Bianchini**  
*Living In Question*  
/ USA /



**Gregg Bissonette**  
*Independent*  
/ USA /



**Brady Blade**  
*Emmylou Harris/Dave Matthews*  
/ USA /



**Kevin Bligh**  
*5606*  
/ USA /

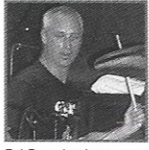

**DJ Bonebrake**  
*X*  
/ USA /



**Rick Brothers**  
*Smoky Lonesome*  
/ USA /



**Jordan Burns**  
*Strung Out*  
/ USA /



**David Calarco**  
*Independent*  
/ USA /



**Will Calhoun**  
*Living Colour*  
/ USA /



**Moe Carlsson**  
*Protest the Hero*  
/ USA /



**Judy Cocuzza**  
*Patsy Grind/*  
/ USA /



**Tony Coleman**  
*B.B. King*  
/ USA /



**Rocky Covington**  
*Bucky Covington*  
/ USA /



**Malcolm Cross**  
*Pete Yorn/Minibar*  
/ USA /



**Nick DeVirgilio**  
*Spock's Beard/ Tears for Fears*  
/ USA /



**Liberty DeVitto**  
*Independent*  
/ USA /



**Marko Djordjevic**  
*The Drummer's Collective*  
/ USA /



**Jim Donovan**  
*Independent*  
/ USA /

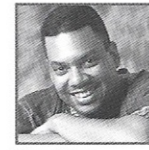

**Vince Ector**  
*Ace Young*  
/ USA /



**Erik Eldenius**  
*Ace Young*  
/ USA /



**Dom Famularo**  
*Master Clinician*  
/ USA /



**Derrick Frost**  
*Chiodos*  
/ USA /



**Mike Hodges**  
*Adrian Belew*  
/ USA /



**Nioshi Jackson**  
*Nashville Star/Sarah Buxton*  
/ USA /



**Rory Koff**  
*No Use For a Name*  
/ USA /



**Trevitt Wingo**  
*The Sword*  
/ USA /



**Matt Wolfe**  
*Byzantine*  
/ USA /



**Jason Marsalis**  
*Independent*  
/ USA /



**Mitch Marine**  
*Dwight Yoakam*  
/ USA /



**Mat Marucci**  
*Cadence/CIMP Recording Artist*  
/ USA /



**Marty Merrill**  
*Duke Ellington*  
/ USA /



**Kevin Miller**  
*Foster Child/Tantric*  
/ USA /



**Mike Novak**  
*Every Time I Die*  
/ USA /



**Doug Pellerin**  
*Independent*  
/ USA /

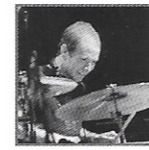

**Chris Pennie**  
*Coheed and Cambria*  
/ USA /



**Darla Rae Perlozzi**  
*Independent*  
/ USA /



**Ralph Peterson Jr.**  
*Berklee College of Music*  
/ USA /



**Wardell Pearson**  
*Vivian Green*  
/ USA /



**Tony Pia**  
*Brian Seizer Orchestra*  
/ USA /



**Keech Rainwater**  
*Lonestar*  
/ USA /



**Walfredo Reyes Jr.**  
*Lindsey Buckingham/Santana*  
/ USA /



**Herlin Riley**  
*Wynton Marsalis*  
/ USA /



**Darrell Robinson**  
*Franklin Bridge*  
/ USA /



**Jerry Roe**  
*Head Automatica/The Wreckers*  
/ USA /



**Fernando Sanchez**  
*Independent*  
/ USA /



**Ty Smith**  
*Bullets and Octane*  
/ USA /



**Glen Sobel**  
*Elliott Yamin*  
/ USA /



**Stacey Lamont Sydnor**  
*Hilary Duff*  
/ USA /



**Erik Tribbett**  
*Kalis/Jill Scott*  
/ USA /



**Tom Van Schaik**  
*Robert Earl Keen*  
/ USA /



**Rashid Williams**  
*Eric Roberson*  
/ USA /



**Stephane Chamberland**  
*Independent*  
/ Canada /



**Tony Albino**  
*Belle et Bum*  
/ Canada /



**Al Hovey**  
*Steve Wrayton Band*  
/ Canada /



**Andrew Stricko**  
*Hello Operator*  
/ Canada /



**Andy Shoniker**  
*Independent*  
/ Canada /



**Bingo Deslauriers**  
*Bob Walsh*  
/ Canada /



**Branden Morgan**  
*Misery Signals*  
/ Canada /



**Brian Craig**  
*Ghoulnautics*  
/ Canada /



**Gordon Wood**  
*France D'Amour*  
/ Canada /



**Ryan Long**  
*The Johnstones*  
/ Canada /



**Curtis Bernard**  
*Independent*  
/ Canada /



**Carlos Araya**  
*Anonymus*  
/ Canada /



**Joel Laprise**  
*That Whaling Band*  
/ Canada /



**Charles Allicy**  
*Your Favorite Enemies*  
/ Canada /



**Josh Trager**  
*Sam Roberts*  
/ Canada /



**Russell Gilbrook**  
*Uriah Heep*  
/ Uk /



**Craig Blundell**  
*Independent*  
/ Uk /



Pete Riley  
*Keith Emerson*  
/ UK /



Neil Cooper  
*Therapy*  
/ UK /



Matt Dabbs  
*Longview*  
/ UK /



Gian Tomaharu  
*Electric Eel Shock*  
/ UK /



Paul Slowley  
*Independent*  
/ UK /



Allan Cox  
*Mamma Mia, Worldwide musical*  
/ UK /



Atton  
*Vengom*  
/ UK /



Hayley Cramer  
*McQueen*  
/ UK /



Jason Bowld  
*PITCHSHIFTER / This is Menace*  
/ UK /



Kevin Clarke  
*Our Lunar Activities*  
/ UK /



Lee Barrat  
*Gallows*  
/ UK /



Neil Cooper  
*Therapy*  
/ UK /



Oliver Askew  
*The Young Knives*  
/ UK /



Rees Bridges  
*Dirty Vegas, Hed Kandi, Session*  
/ UK /



Ric Lee  
*Then Years After*  
/ UK /



Toby Goodman  
*Session*  
/ UK /



Bruno Mathieu  
/ France /



Claude Salmieri  
/ France /



Charlie Poggio  
*with Axel Bauer*  
/ France /



Frankly Costanza  
*Dagoba*  
/ France /



Fred Villard  
*Independent*  
/ France /



Jon Grandcamp  
/ France /



Micheal Desir  
*Independent*  
/ France /



Piwee  
/ France /



Simon Tellier  
/ France /



Bas Sluis  
*Independent*  
/ France /



Alexander Murenko  
*Independent*  
/ Ukraine /



Klaudius Kryspin  
*Prazsky Vyber II*  
/ Czech /



Martin Vajgl  
*Independent*  
/ Czech /



Radek Brichac  
*David Kraus Band*  
/ Czech /



Zdenek Steiner  
*WOHNOUT, DEVIL'S AUTUMN*  
/ Czech /



Pete Eyre  
/ Sweden /



Adam Pedretti  
*Killing Heidi*  
/ Australia /



Dave Mathews  
*Independent*  
/ Australia /



Ian Jones  
*Independent*  
/ Australia /



Luke Casey  
*Tinpot Guru*  
/ New Zealand /



Alfredo Golino  
*Independent*  
/ Italy /



Giovanni Pezzoli  
*Independent*  
/ Italy /



Adriano Molinari  
*Independent*  
/ Italy /



Giorgio Di Tullio  
*Independent*  
/ Italy /



Andy Gillmann  
*Author*  
/ Germany /



Felix Bohnke  
*Edguy*  
/ Germany /



Stefan Arnold  
*Grave Digger*  
/ Germany /



Randy Black  
*Primal Fear*  
/ Germany /



Patrick Grün  
*Caliban*  
/ Germany /



Dirk Rosenbaum  
*Bushido*  
/ Germany /



Sven Hansen  
*Stigma*  
/ Germany /



Bernd Herrmann  
*Söhne Mannheims*  
/ Germany /



Claus Hessler  
*Teacher*  
/ Germany /



Willy Ketzner  
*Paul Leim, WK Trio*  
/ Germany /



Sebastian Krajewski  
*Seeed*  
/ Germany /



Markus Leukel  
*Mark Gillespie*  
/ Germany /



Karin-Anna Liedel  
*Independent*  
/ Germany /



Hans Schlotter  
*Sara Kuttner TV*  
/ Germany /



Werner Schmitt  
*Independent*  
/ Germany /



Evgeniy Shestopalov  
*Independent*  
/ Germany /



Jürgen Stiehle  
*Die Happy*  
/ Germany /



Tomas Váth  
*Allstar TV Band*  
/ Germany /



Matthias Voigt  
*Heaven Shall Burn*  
/ Germany /



Harald Wenzek  
*Independent*  
/ Germany /



Andy Winter  
*Andy Winter Group*  
/ Germany /



Sascha Carrilho  
*4 Lyn*  
/ Germany /



Otti Bauer  
*Otti Bauer Orchester*  
/ Germany /



Dirk Brand  
*Independent*  
/ Germany /



Klaus Pérez  
*Christina Stürmer*  
/ Germany /



Stefan Breuer  
*The Busters*  
/ Germany /



Tobi Danne  
*Itchy Poopkizd*  
/ Germany /



Daniel Fleischmann  
*Peter Seiler*  
/ Germany /



Stefan Gemballa  
*Flowing Tears*  
/ Germany /



Andreas Lill  
*Vanden Plas*  
/ Germany /



Gerd Lücking  
*Rebellion*  
/ Germany /



Lui Ludwig  
*Uwe Ochsenknecht, Julie Neigel*  
/ Germany /



Jan Mischon  
*Courageous*  
/ Germany /



Markus Müller  
*Independent*  
/ Germany /



Sven Polkötter  
*Claus Grabke Band*  
/ Germany /



Vom Ritchie  
*Die Toten Hosen*  
/ Germany /



Vladi Jäggy  
*Independent*  
/ Switzerland /



Nick Wachsmuth  
*Maroon*  
/ Germany /



Thomas Fischer  
*Guido Horn*  
/ Germany /



Wolfgang Jonas  
*Highly*  
/ Germany /



Jordi Geuens  
*Postman*  
/ Germany /



Jusso Whistler  
*Independent*  
/ Germany /



Mario Meister  
*Independent*  
/ Germany /



Tim Schwarz  
*Bloodflowerz*  
/ Germany /



Peter Haas  
*Independent*  
/ Switzerland /



Laurent Biollay  
*Stress, Sens Unki, Zorg*  
/ Switzerland /



Christian Bisang  
*Independent*  
/ Switzerland /

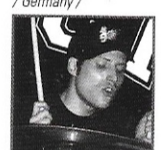

Lukas Frohofer  
*Snitch*  
/ Switzerland /



Toshio Yakkatokuo  
*Phillip Fankhauser*  
/ Switzerland /



Andy Waar  
*Independent*  
/ Switzerland /



Domenico Russo  
*Antunez, Independent, Kim*  
/ Switzerland /



Roland Ghobril  
/ Lebanon /



Cezary Konrad  
*Independent*  
/ Poland /



Artur Malik  
*Funk de Nite*  
/ Poland /

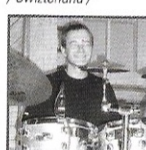

Slawomir Berny  
*Turnau*  
/ Poland /



Mark Atso  
*Metsatöll, Loits*  
/ Estonia /



Denis Shakhanov  
*Lumen*  
/ Russia /



Peter Ivshin  
*Julia Savicheva*  
/ Russia /



Grigory Gaberman  
*Philip Kirkorov, Leysa Pesnya*  
/ Russia /

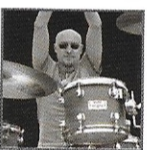

Michael Kraev  
*Zveri*  
/ Russia /



Denis Kuptsov  
*Spiritfire, Leningrad, St. Petersburg Ska-Jazz Review*  
/ Russia /



Denis Markinkin  
*Zeitnot, Zemfira*  
/ Russia /

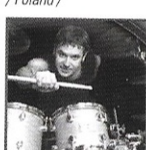

Sergey Navetny  
*Solo project "Nava"*  
/ Russia /

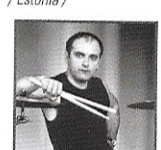

Oleg Pungin  
*Mummy Troll*  
/ Russia /



Dmitry Khabirov  
*Smislovie Galluzinazi*  
/ Russia /



Sandor Meszaros  
*Independent*  
/ Hungary /



Marcell Romanek  
*NOISE*  
/ Hungary /



Peter Csorba  
*Independent*  
/ Hungary /



Alejandro Collados  
*Cabezones*  
/ Argentina /



Antonio Trapanotto  
*Soledad Pastorutti*  
/ Argentina /



Marcelo Mira  
*Memphis, La Blusera*  
/ Argentina /



Gustavo Meli  
/ Argentina /



Jorge "Tanque" Iglesias  
*La Renga*  
/ Argentina /



Andy Vilanova  
*Carajo*  
/ Argentina /



Mauricio "Topo" Espindola  
*Skay Beilinson*  
/ Argentina /



Esteban Kubista  
*Kyosko*  
/ Argentina /



Sergio Vall  
*Los Violadores*  
/ Argentina /



Sandy Andarusman  
*PAS Band*  
/ Indonesia /



Seno Aji Wibowo  
*RADJA*  
/ Indonesia /



Konde/Chandra Christanto  
*SAMSON*  
/ Indonesia /



Gerry Herb  
*KRAKATAU*  
/ Indonesia /



Posan  
*KOTAK*  
/ Indonesia /



Alsa  
/ Indonesia /



Aniket Waghmode  
*Sceptre*  
/ India /



Reuban  
*Illrd Sovereign*  
/ India /



Ryan Colaco  
*Kryptos*  
/ India /



Virendra Kaith  
*Demonic Resurrection, Pin Drop Violence, Prayag*  
/ India /



Rahul Hariharan  
*Bhayanak Maut/Red Cube*  
/ India /



Javier Barrera  
*BA/La Quinta Estación*  
/ Mexico /



Waldo Madera  
*Ricky Martin, Juanes*  
/ Mexico /



Dudu Portes  
*Independent, producer*  
/ Brazil /



Aquiles Priestter  
*Angra*  
/ Brazil /



Norival D'angelo  
*Roberto Carlos, Rockfeller*  
/ Brazil /



Ricardo Japinha  
*CPM22*  
/ Brazil /



Christian Hirth  
*Media Banda*  
/ Chile /

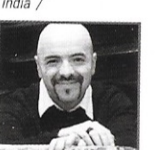

Manuel Páez  
/ Chile /



Ibon Jordan  
*Independent*  
/ Spain /



Ruben Mol  
*Independent*  
/ Spain /



Felip Santandreu  
*Independent*  
/ Spain /



Toni Mateos  
*Independent*  
/ Spain /



Pere Foved  
*Independent*  
/ Spain /



Juni  
*El Combo Lingo*  
/ Spain /



Ivan Ramirez  
*Ebony Ark*  
/ Spain /



Jose Ramon Jimenez  
*"Serra" Circus*  
/ Spain /



Eva Benito  
Morgana  
/ Spain /



Andres Cobos "Andy"  
Saratoga  
/ Spain /



Javier Herrero  
Independent  
/ Spain /



Angel Crespo  
/ Spain /



Yayo Morales  
Independent  
/ Spain /



Enma Louise Brodie  
Independent  
/ Spain /



Angel Celada  
/ Spain /



Lucas Jimenez  
Independent  
/ Spain /



Carlos Carli  
/ Spain /



Ramón Ángel Rey  
/ Spain /



Pepe Sanchez  
/ Spain /



Paco García  
/ Spain /



José A. Pereira  
/ Spain /



Eric Franklin  
/ Spain /



Christopher Farfán  
/ Peru /



Alvaro Escobar Picasso  
Era  
/ Peru /



Jorge Forero  
Atwesta, Osario project  
/ Colombia /



Blu Martinez  
Independent  
/ Colombia /



Daniel Segura  
Independent  
/ Colombia /



Frank Calzadilla  
/ Colombia /



Einar Escaf  
/ Colombia /



Bei Bei  
Cui Jian Band  
/ China /





Product specifications described herein are subject to change without notice.

Due to limitations in photographic and lithographic processes, illustrated colors may vary slightly from actual colors offered. Since wood grain patterns appear randomly in raw materials, wood grain on product pictured will differ from actual product. Cymbals are not included, except where indicated. Some items may only be available via special order, see dealer for details.

Black Panther™, ITS™, OS Cymbal Accentuators™ and Tri-Nodal™ are trademarks of Mapex USA, Incorporated.

Remo® is a registered trademark of Remo, Inc. Zildjian® is a registered trademark of Avedis Zildjian Company.

© Copyright 2008 Printed in China



MAPEXDRUMS.COM

PMKM-M2008E